

ACTUATOR

ACTUATOR

ADVANTAGES	G-2
LIST OF AVAILABLE BG·BH	G-4
RATED LIFE	G-6

BG TYPE

BG PART NUMBER STRUCTURE	G-10
BG SPECIFICATIONS	G-12
BG ALLOWABLE SPEED AND STROKE LIMIT	G-13
BG ACCURACY	G-14
BG DIMENSION TABLE	G-16
BG MOTOR BRACKET CONFIGURATIONS & APPLICABLE MOTORS	G-32
BG EXPOSED BRACKET R0	G-48
BG RETURN PULLEY UNIT	G-50
BG LOW HOUSING	G-52
BG BELLOWS	G-54
BG SENSOR	G-63
BG PNP SENSOR	G-74
BG POSITIONING PIN HOLE	G-75
BG LUBRICATION	G-80
BG 2 AXES COMBINED BRACKET	G-81

BH TYPE

BH PART NUMBER STRUCTURE	G-82
BH SPECIFICATIONS	G-84
BH ALLOWABLE SPEED AND STROKE LIMIT	G-85
BH ACCURACY	G-86
BH DIMENSION TABLE	G-88
BH MOTOR BRACKET CONFIGURATIONS & APPLICABLE MOTORS	G-98
BH EXPOSED BRACKET R0	G-108
BH RETURN PULLEY UNIT	G-109
BH SENSOR	G-111
BH PNP SENSOR	G-117
BH POSITIONING PIN HOLE	G-118
BH LUBRICATION	G-122

ACTUATOR APPENDIX

USE AND HANDLING PRECAUTIONS	G-123
OPERATING TEMPERATURE	G-123
LUBRICATION	G-123
SENSOR SPECIFICATIONS	G-124

ACTUATOR

ADJUSTMENT FREE, SPACE SAVING, HIGH ACCURACY, HIGH RIGIDITY

SINGLE AXIS ACTUATOR

BG·BH series is a compact single axis actuator which integrates a slide guide and precision ballscrew.



ADVANTAGES

Adjustment Free (Built-in support unit)

Built-in support unit and integration of the slide guide and precision ballscrew eliminates complex precision adjustment and reduces installation time dramatically.

Space Saving (Low height profile)

The "U" shaped guide rail and integrated slide block and precision ballscrew make compact designs.

Figure G-1 Structure

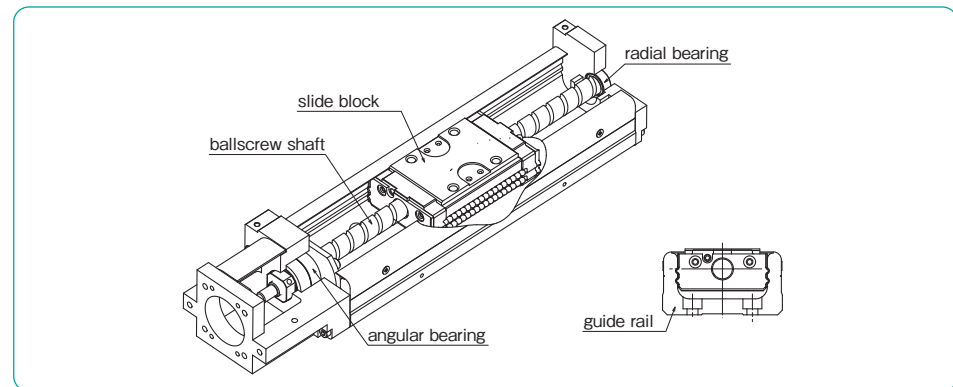

High Accuracy (Precisely evaluated, precisely guaranteed)

BG series precision grade (P) guarantees positioning repeatability $\pm 1 \mu\text{m}$. Inspection data sheet is attached to BG series only, measured value can be confirmed.

Table G-1 Accuracy

part number	BG series		BH series	
accuracy grade symbol	P grade	H grade	U grade	W grade
positioning repeatability	$\pm 1 \mu\text{m}$	$\pm 3 \mu\text{m}$	$\pm 5 \mu\text{m}$	$\pm 10 \mu\text{m}$

High Rigidity (Gothic arch groove profile)

Four or two-circuit and four-point contact structure in linear motion part provide very high rigidity. And "U" shaped guide rail provide very high rigidity against bending moment and deflection and can be used for cantilevered application.

Figure G-2 Block Displacement against Radial Load

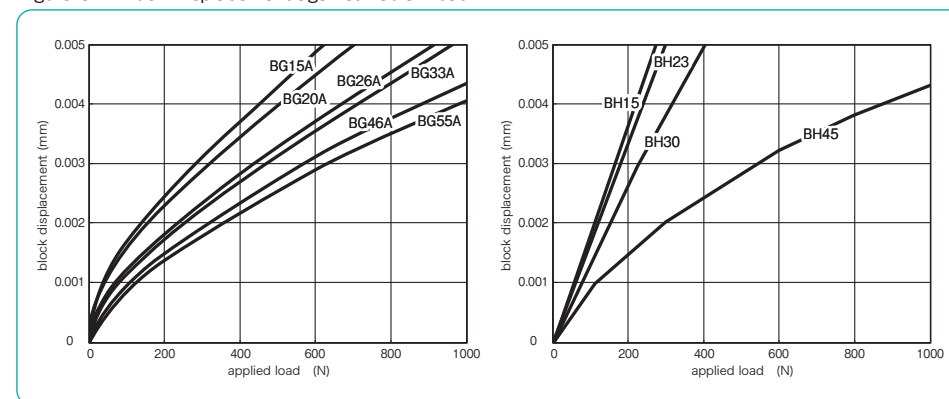

Figure G-3 Ball Contact Profile

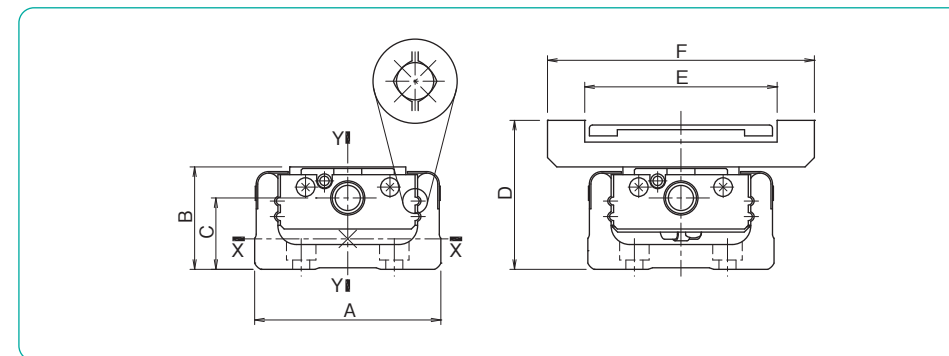

Table G-2 Cross-sectional Dimensions · Moment of Inertia of Area of Guide Rail

part number	A	B	C	D	E	F	moment of inertia of area(mm ⁴)		mass W (kg/100mm)
							I _x (X Axis)	I _y (Y Axis)	
BG15	30	15	9.5	25	32	44	1.22×10^3	1.56×10^4	0.12
BG20	40	20	12.5	32	37	52	6.50×10^3	6.00×10^4	0.25
BG26	50	26	16	40	47	62	1.69×10^4	1.47×10^5	0.38
BG33	60	33	18	48	62	86	5.11×10^4	3.42×10^5	0.60
BG46	86	46	32	68	88	112	2.42×10^5	1.49×10^6	1.24
BG55	100	55	32	80	95	124	2.29×10^5	2.28×10^6	1.50
part number	A	B	C	D	E	F	moment of inertia of area(mm ⁴)		mass W (kg/100mm)
							I _x (X Axis)	I _y (Y Axis)	
BH15	30	15	10	25	32	44	2.71×10^3	2.36×10^4	0.15
BH23	50.5	23	15.4	36	42	57	1.44×10^4	1.37×10^5	0.41
BH30	60.5	30	21.3	45	61	80	3.88×10^4	3.14×10^5	0.56
BH45	86.5	45	31.5	67	88	112	1.45×10^5	1.26×10^6	1.11

RATED LIFE

To obtain the rated life of the BG·BH type, calculate the rated life of the guide portion, ballscrew portion and support bearing portion. Use the minimum value as the rated life of the BG and BH type.

A. Life of Guide Portion

Use the following equation for calculating the rated life of guide portion.

$$L_G = \left(\frac{f_c}{f_w} \cdot \frac{C}{P_T} \right)^3 \cdot 50 \dots\dots\dots (1)$$

L_G : rated life (km) f_c : contact coefficient (refer to Table G-6)
 f_w : applied load coefficient (refer to Table G-7) C : basic dynamic load rating (N)
 P_T : calculated load applied to one block (N)

A.1. Calculation of P_T

Before calculating the rated life using the equation (1), the calculated load applied to one block (P_T) needs to be obtained in consideration of the moment load, etc. that will be actually applied.

For rapidly-accelerating or short stroke motion, P_T needs to be calculated with acceleration taken into consideration. The calculation of this acceleration will be carried out for the mass applied to BG·BH. Obtain the calculated load during uniform motion, acceleration, and deceleration, and use the average value of the three as P_T .

For the calculation of P_T , select an appropriate equation depending on the installation conditions of the guide.

It is also possible to calculate P_T without including the effect of acceleration by using the equation " $P_T = P_{TC}$ (see the equations (2), (5), and (8)). In this case, however, the obtained value is a rough approximation, so a selection with sufficient margin is recommended.

Table G-6 Contact Coefficient (f_c)

number of blocks in close contact on one axis	contact coefficient (f_c)
1	1.0
2	0.81

Table G-7 Applied Load Coefficient (f_w)

operating conditions		applied load coefficient (f_w)
vibration, impact	velocity	
none	0.25m/s or less	1.0 ~ 1.5
low	1m/s or less	1.5 ~ 2.0
high	1m/s or more	2.0 ~ 3.5

Table G-8 Moment Equivalent Coefficient

part number	E_P (E2P)	E_Y (E2Y)	E_R (E2R)
BG15□□A	2.82×10^{-1}	2.37×10^{-1}	9.35×10^{-2}
BG15□□B	5.16×10^{-2}	4.33×10^{-2}	4.67×10^{-2}
BG20□□A	2.25×10^{-1}	1.89×10^{-1}	7.84×10^{-2}
BG20□□B	3.98×10^{-2}	3.34×10^{-2}	3.92×10^{-2}
BG26□□A	1.51×10^{-1}	1.27×10^{-1}	5.88×10^{-2}
BG26□□B	2.72×10^{-2}	2.28×10^{-2}	2.94×10^{-2}
BG33□□A	1.26×10^{-1}	1.06×10^{-1}	4.55×10^{-2}
BG33□□B	2.20×10^{-2}	1.84×10^{-2}	2.27×10^{-2}
BG33□□C	2.31×10^{-1}	1.94×10^{-1}	4.55×10^{-2}
BG33□□D	3.09×10^{-2}	2.59×10^{-2}	2.27×10^{-2}
BG46□□A	8.39×10^{-2}	7.04×10^{-2}	3.17×10^{-2}
BG46□□B	1.56×10^{-2}	1.31×10^{-2}	1.59×10^{-2}
BG46□□C	1.39×10^{-1}	1.17×10^{-1}	3.17×10^{-2}
BG46□□D	2.15×10^{-2}	1.81×10^{-2}	1.59×10^{-2}
BG55□□A	6.80×10^{-2}	5.71×10^{-2}	2.74×10^{-2}
BG55□□B	1.35×10^{-2}	1.14×10^{-2}	1.37×10^{-2}
BH15□□A	2.70×10^{-1}	2.45×10^{-1}	9.64×10^{-2}
BH15□□B	4.50×10^{-2}	3.80×10^{-2}	4.82×10^{-2}
BH23□□A	1.52×10^{-1}	1.37×10^{-1}	5.22×10^{-2}
BH23□□B	2.54×10^{-2}	2.29×10^{-2}	2.61×10^{-2}
BH30□□A	1.17×10^{-1}	9.83×10^{-2}	4.54×10^{-2}
BH30□□B	1.95×10^{-2}	1.64×10^{-2}	2.27×10^{-2}
BH45□□A	8.39×10^{-2}	7.04×10^{-2}	3.17×10^{-2}
BH45□□B	1.56×10^{-2}	1.31×10^{-2}	1.59×10^{-2}
BH45□□C	1.26×10^{-1}	1.06×10^{-1}	3.17×10^{-2}
BH45□□D	2.10×10^{-2}	1.76×10^{-2}	1.59×10^{-2}

*The E2 coefficient is for two blocks being used in close contact.

A.1.a. P_T for Horizontal Move (Horizontal Mounting)

i) during uniform motion (P_{TC})

$$P_{TC} = \frac{1}{n} \cdot W + E_P \cdot M_{PL} + E_Y \cdot M_{YL} + E_R \cdot M_{RL} \dots\dots\dots (2)$$

ii) during acceleration (P_{Ta})

$$P_{Ta} = \frac{1}{n} \cdot W + E_P(M_{PL} + m \cdot \alpha_a \cdot Z) + E_Y(M_{YL} + m \cdot \alpha_a \cdot X) + E_R \cdot M_{RL} \dots\dots\dots (3)$$

Note that the values of ($M_{PL} + m \cdot \alpha_a \cdot Z$) and ($M_{YL} + m \cdot \alpha_a \cdot X$) will be treated as 0 (zero) when the calculated value is negative.

iii) during deceleration (P_{Td})

$$P_{Td} = \frac{1}{n} \cdot W + E_P(M_{PL} + m \cdot \alpha_d \cdot Z) + E_Y(M_{YL} + m \cdot \alpha_d \cdot X) + E_R \cdot M_{RL} \dots\dots\dots (4)$$

Note that the values of ($M_{PL} + m \cdot \alpha_d \cdot Z$) and ($M_{YL} + m \cdot \alpha_d \cdot X$) will be treated as 0 (zero) when the calculated value is negative.

P_{TC} : calculated load applied to a block during uniform motion (N) P_{Ta} : calculated load applied to a block during accelerating (N)
 P_{Td} : calculated load applied to a block during decelerating (N) n : number of blocks of BG·BH W : applied load (N) m : carrying mass (kg)

α_a : acceleration during accelerating (m/sec²) α_d : acceleration during decelerating (m/sec²) (the negative value)
 X : distance between the center of BG·BH and the center of the carrying mass (mm) Y : distance between the center of BG·BH and the center of the carrying mass (mm)
 Z : distance between the center of BG·BH ballscrew and the center of the carrying mass (mm) E_P : moment equivalent coefficient in the pitching direction (refer to Table G-8)

E_Y : moment equivalent coefficient in the yawing direction (refer to Table G-8) E_R : moment equivalent coefficient in the rolling direction (refer to Table G-8)

M_{PL} : applied moment in the pitching direction (N·mm) $M_{PL} = W \cdot Y$

M_{YL} : applied moment in the yawing direction (N·mm) $M_{YL} = 0$ (This case is not applicable)

M_{RL} : applied moment in the rolling direction (N·mm) $M_{RL} = W \cdot X$ *Refer to Fig. G-8 for the direction of moment.

A.1.b. P_T for Horizontal Move (Wall Mounting)

i) during uniform motion (P_{TC})

$$P_{TC} = \frac{1}{1.19 \cdot n} \cdot W + E_P \cdot M_{PL} + E_Y \cdot M_{YL} + E_R \cdot M_{RL} \dots\dots\dots (5)$$

ii) during acceleration (P_{Ta})

$$P_{Ta} = \frac{1}{1.19 \cdot n} \cdot W + E_P(M_{PL} + m \cdot \alpha_a \cdot Z) + E_Y(M_{YL} + m \cdot \alpha_a \cdot X) + E_R \cdot M_{RL} \dots\dots\dots (6)$$

Note that the values of ($M_{PL} + m \cdot \alpha_a \cdot Z$) and ($M_{YL} + m \cdot \alpha_a \cdot X$) will be treated as 0 (zero) when the calculated value is negative.

iii) during deceleration (P_{Td})

$$P_{Td} = \frac{1}{1.19 \cdot n} \cdot W + E_P(M_{PL} + m \cdot \alpha_d \cdot Z) + E_Y(M_{YL} + m \cdot \alpha_d \cdot X) + E_R \cdot M_{RL} \dots\dots\dots (7)$$

Note that the values of ($M_{PL} + m \cdot \alpha_d \cdot Z$) and ($M_{YL} + m \cdot \alpha_d \cdot X$) will be treated as 0 (zero) when the calculated value is negative.

P_{TC} : calculated load applied to a block during uniform motion (N) P_{Ta} : calculated load applied to a block during accelerating (N)
 P_{Td} : calculated load applied to a block during decelerating (N) n : number of blocks of BG·BH W : applied load (N) m : carrying mass (kg)

α_a : acceleration during accelerating (m/sec²) α_d : acceleration during decelerating (m/sec²) (the negative value)
 X : distance between the center of BG·BH and the center of the carrying mass (mm) Y : distance between the center of BG·BH and the center of the carrying mass (mm)
 Z : distance between the center of BG·BH ballscrew and the center of the carrying mass (mm) E_P : moment equivalent coefficient in the pitching direction (refer to Table G-8)

E_Y : moment equivalent coefficient in the yawing direction (refer to Table G-8) E_R : moment equivalent coefficient in the rolling direction (refer to Table G-8)

M_{PL} : applied moment in the pitching direction (N·mm) $M_{PL} = 0$ (This case is not applicable)

M_{YL} : applied moment in the yawing direction (N·mm) $M_{YL} = W \cdot Y$

M_{RL} : applied moment in the rolling direction (N·mm) $M_{RL} = W \cdot Z$ *Refer to Fig. G-8 for the direction of moment.

Figure G-4

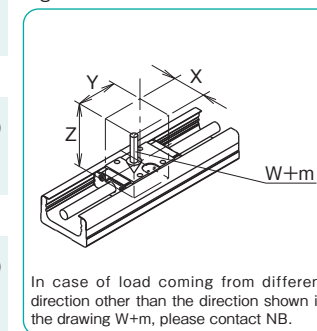
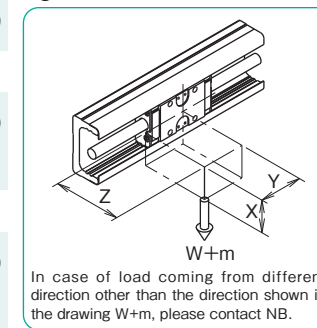

Figure G-5



A.1.c. P_T for Vertical Move

i) during uniform motion (P_{Tc})

$$P_{Tc} = E_P \cdot M_{PL} + E_Y \cdot M_{YL} + E_R \cdot M_{RL} \dots\dots\dots (8)$$

ii) during acceleration (P_{Ta})

$$P_{Ta} = E_P(M_{PL} + m \cdot a_a \cdot Z) + E_Y(M_{YL} + m \cdot a_a \cdot X) + E_R \cdot M_{RL} \dots\dots\dots (9)$$

Note that the values of (M_{PL}+m·a_a·Z) and (M_{YL}+m·a_a·X) will be treated as 0 (zero) when the calculated value is negative.

iii) during deceleration (P_{Td})

$$P_{Td} = E_P(M_{PL} + m \cdot a_d \cdot Z) + E_Y(M_{YL} + m \cdot a_d \cdot X) + E_R \cdot M_{RL} \dots\dots\dots (10)$$

Note that the values of (M_{PL}+m·a_d·Z) and (M_{YL}+m·a_d·X) will be treated as 0 (zero) when the calculated value is negative.

P_{Tc}: calculated load applied to a block during uniform motion (N) P_{Ta}: calculated load applied to a block during accelerating (N)
 P_{Td}: calculated load applied to a block during decelerating (N) n: number of blocks of BG·BH W: applied load (N) m: carrying mass (kg)
 a_a: acceleration during accelerating (m/sec²) a_d: acceleration during decelerating (m/sec²) (the negative value)
 X: distance between the center of BG·BH and the center of the carrying mass (mm) Y: distance between the center of BG·BH and the center of the carrying mass (mm)
 Z: distance between the center of BG·BH ballscrew and the center of the carrying mass (mm) E_P: moment equivalent coefficient in the pitching direction (refer to Table G-8)
 E_Y: moment equivalent coefficient in the yawing direction (refer to Table G-8) E_R: moment equivalent coefficient in the rolling direction (refer to Table G-8)
 M_{PL}: applied moment in the pitching direction (N·mm) M_{PL}=W·Z M_{YL}: loaded moment in the yawing direction (N·mm) M_{YL}=W·X
 M_{RL}: applied moment in the rolling direction (N·mm) M_{RL}=0 *Refer to Figure G-8 for the direction of moment.

Figure G-6

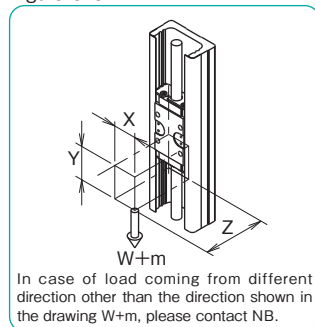

A.1.d.

Obtain the calculated load applied to a block (P_T) by calculating the average load of each motion using an appropriate equation among those shown above according to the application.

$$P_T = \sqrt[3]{\frac{1}{(S1+S2+S3)} (P_{Ta}^3 \cdot S1 + P_{Tc}^3 \cdot S2 + P_{Td}^3 \cdot S3)} \dots\dots\dots (11)$$

P_T: calculated load applied to one block (N)
 S1: travel distance during acceleration (mm) (refer to Figure G-7)
 S2: travel distance during uniform motion (mm) (refer to Figure G-7)
 S3: travel distance during deceleration (mm) (refer to Figure G-7)
 P_{Ta}: calculated load applied to one block during accelerating (N)···equation (3), (6), and (9)
 P_{Tc}: calculated load applied to one block during uniform motion (N)···equation (2), (5), and (8)
 P_{Td}: calculated load applied to one block during decelerating (N)···equation (4), (7), and (10)

Figure G-7

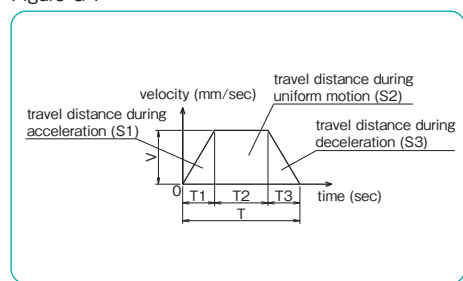

B. Life of Ballscrew and Support Bearing

The life of ballscrew and support bearing can be calculated using a common equation, as shown below. Compare the dynamic load rating of the ballscrew and the support bearing and apply smaller value for calculation.

$$L_a = \left(\frac{1}{f_w} \cdot \frac{C_a \text{ or } C_b}{P_a} \right)^3 \cdot \ell \dots\dots\dots (12)$$

L_a: rated life (km) f_w: applied load coefficient (refer to Table G-7)
 C_a: basic dynamic load rating of the ballscrew (N)
 C_b: basic dynamic load rating of the support bearing (N)
 P_a: axial load (N) ℓ: ballscrew lead (mm)

B.1. Calculation of P_a

Before calculating the life using the equation (12), calculate P_a with acceleration taken into consideration. Calculate the load in each axial direction during uniform motion, acceleration, and deceleration and the obtained value is used as P_a.

B.1.a. For Horizontal Move

i) during uniform motion (P_{ac})

$$P_{ac} = \mu \cdot W + F + f_b \cdot n \dots\dots\dots (13)$$

ii) during acceleration (P_{aa})

$$P_{aa} = \mu \cdot W + F + f_b \cdot n + (m + m_b \cdot n) a_a \dots\dots\dots (14)$$

iii) during deceleration (P_{ad})

$$P_{ad} = \mu \cdot W + F + f_b \cdot n + (m + m_b \cdot n) a_d \dots\dots\dots (15)$$

B.1.b. For Vertical Move

i) during uniform motion (P_{ac})

$$P_{ac} = (m + m_b \cdot n)g + F + f_b \cdot n \dots\dots\dots (16)$$

ii) during acceleration (P_{aa})

$$P_{aa} = (m + m_b \cdot n) \cdot (g + a_a) + F + f_b \cdot n \dots\dots\dots (17)$$

iii) during deceleration (P_{ad})

$$P_{ad} = (m + m_b \cdot n) \cdot (g + a_d) + F + f_b \cdot n \dots\dots\dots (18)$$

B.1.c.

Obtain the average axial load (P_a) using an appropriate formula among those shown above depending on the application.

$$P_a = \sqrt[3]{\frac{1}{(S1+S2+S3)} (|P_{aa}|^3 \cdot S1 + |P_{ac}|^3 \cdot S2 + |P_{ad}|^3 \cdot S3)} \dots\dots\dots (19)$$

P_a: average axial load (N)
 S1: travel distance during acceleration (mm) (refer to Figure G-7)
 S2: travel distance during uniform motion (mm) (refer to Figure G-7)
 S3: travel distance during deceleration (mm) (refer to Figure G-7)
 P_{aa}: axial load during accelerating (N)···equation (14) and (17)
 P_{ac}: axial load during uniform motion (N)···equation (13) and (16)
 P_{ad}: axial load during decelerating (N)···equation (15) and (18)

Table G-9 Dynamic Frictional Resistance (f_b) of a Single Block (Seal Resistance) unit: N

part number	U/W grade
BH15	2.0
BH23	2.5
BH30	2.5
BH45	7.5

part number	high (H)	precision (P)
BG15	0.8	1.8
BG20	2.3	4.9
BG26	5.4	9.8
BG33	4.4	10.2
BG46	7.4	13.3
BG55	9	16

P_{ac}: axial load rating during uniform motion (N)
 P_{aa}: axial load rating during accelerating (N)
 P_{ad}: axial load rating during decelerating (N)
 μ: friction coefficient (0.006) W: load applied to a block (N)
 F: external force (load) applied to the axial direction (N)
 f_b: sliding resistance of a single block (N) (refer to Table G-9)
 n: number of blocks of BG·BH m: carrying mass (kg)
 m_b: mass of a block of BG·BH (kg) (refer to page G-16~31 for BG type, page G-88~97 for BH type)
 a_a: acceleration during accelerating (m/sec²)
 a_d: acceleration during decelerating (m/sec²) (the negative value)
 g: acceleration of gravity (9.8m/sec²)

BG TYPE

PART NUMBER STRUCTURE

Part number for BG type is described as follows.

①	②	③	④	⑤	⑥	⑦	⑧	⑨	⑩
BG	15	01	A	75	H	A0	L	K	P△□
		02	B	100	P	A1	C	KN	G▲
				125		A2	J○○		LB
				150		A3			PNP
				175		A4			
				200		A5			
						A6			
						A7			
						RO			

①	②	③	④	⑤	⑥	⑦	⑧	⑨	⑩
BG	26	02	A	150	H	A0	L	S	P△□
		05	B	200	P	A1	C	K	G▲
				250		A3	J○○	SN	LB
				300		A5		KN	PNP
						A6			
						A8			
						A9			
						AA			
						RO			

①	②	③	④	⑤	⑥	⑦	⑧	⑨	⑩
BG	46	10	A	340	H	A0	L	S	P△□
		20	B	440	P	A1	C	H	G▲
			C	540		A2	J○○	K	LB
			D	640		A3			PNP
				740		A4		SN	
				840		B0		HN	
				940		CO		KN	
				1040		DO			
				1140		D1			
				1240		RO			
						RA□			
						RB□			
						RC□			

*Short blocks are not available for BG3320.

There is limitation on the length of rails depending on block type and accuracy grade. Please refer to page G-13~14 for details.

- ① BG type
- ② size
- ③ ballscrew lead (refer to page G-12)
- ④ type of block

A: 1 long block

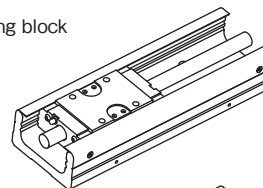

B: 2 long blocks

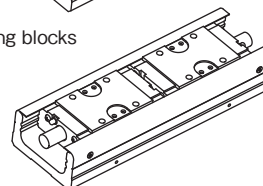

C: 1 short block

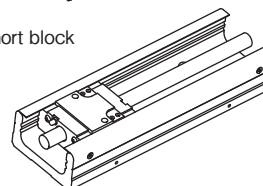

D: 2 short blocks

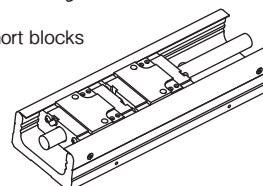

- ⑧ cover, low housing and bellows
none: without top cover
(refer to page G-16~)

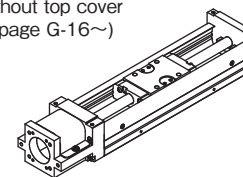

L: low housing
(refer to page G-52~)

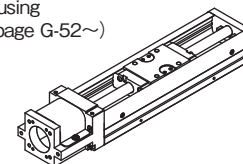

C: with top cover + sub table
(refer to page G-17~)

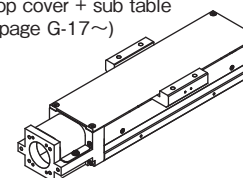

J○○: with bellows
(refer to page G-54~)

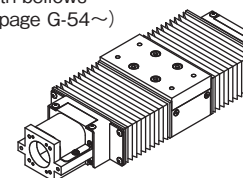

*Drive block is located closest to motor bracket side.

⑤ guide rail length

*Precision grade(P) has limitation on the length of rails. Please refer to page G-14 for details.

⑥ accuracy grade (refer to page G-14)

H	high grade
P	precision grade

⑦ motor bracket (refer to page G-32~35)

The number in the square □ after suffix RA, RB or RC indicates the mounting direction code. (refer to page G-50~51)

⑩ option

none	without option
P△□	with positioning pin hole (*1)
G▲	with special grease option (*2)
LB	with low temperature black chrome treatment (*3)
PNP	with PNP sensor

In case of multiple options, add + between each option. Example: (PS+LB+PNP)

○○ sensor cable outlet position
(refer to page G-54)

⑨ sensor (refer to page G-63~)

none	without sensor
S	with slim-type / compact photomicro sensor
H	with close contact capable photomicro sensor
K	with proximity sensor
SN	S Specification without sensor
HN	H Specification without sensor
KN	K Specification without sensor

SN,HN, KN are attached with sensor rail and sensor dog only. No sensor is attached.

*1: △ is S, W or R (refer to page G-75)
□ is R (refer to page G-75)

*2: ▲ is U, L or F (refer to page G-80)
Grease is applied to slide guide, ballscrew, and angular bearings.

*3: LB is applied to steel parts except for aluminum parts and radial bearings.
For BG15, LB is applied to steel parts except for the drive block, aluminum parts, and radial bearings. Black chrome treatment is applied to the drive block.

SPECIFICATIONS

BG Type is categorized as either high grade (H) or precision grade (P). Precision grade(P) has limitation on the length of rails. (Please refer to page G-14.)

Table G-10 Specifications

part number		BG1501	BG1502	BG2001	BG2005	BG2602	BG2605	BG3305	BG3310	BG3320	BG4610	BG4620	BG5520											
accuracy grade		high	precision	high	precision	high	precision	high	precision	high	precision	high	precision											
radial clearance		μm	-2~0	-4~-2	-2~0	-4~-2	-3~0	-6~-3	-3~0	-6~-3	-4~0	-8~-4	-4~0	-8~-4	-3~0	-7~-3	-3~0	-7~-3	-5~0	-11~-5	-5~0	-11~-5	-6~0	-18~-6
guide	basic dynamic load C	kN	2.42	4.27	7.87	12.6	29.8	43.2																
		N-m	17	35	99	181	610	1,088																
	basic static load Co	kN	4.76	7.89	14.98	22.7	51.2	74.0																
		N-m	92	199	550	1,035	3,285	5,465																
	allowable static moment	My	N-m	20	42	118	215	727	1,297															
		M2y	N-m	110	237	656	1,233	3,914	6,513															
		Mx	N-m	51	101	255	500	1,612	2,701															
		M2x	N-m	102	201	509	1,000	3,224	5,402															
	short block	basic dynamic load C	kN	—	—	—	7.8	—	19.9	—														
			N-m	—	—	—	49	—	207	—														
basic static load Co		kN	—	—	—	11.4	—	28.8	—															
		N-m	—	—	—	368	—	1,336	—															
allowable static moment		My	N-m	—	—	—	59	—	246	—														
		M2y	N-m	—	—	—	439	—	1,593	—														
ball screw	shaft diameter	mm	6	6	8	10	12	15	20															
		lead	mm	1	2	1	5	2	5	5	10	20	10	20	20									
bearing support	spacer-ball ratio	—	—	—	—	—	—	1:1	—	1:1	—	1:1	—	2:1	—	2:1								
		basic dynamic load Ca	kN	0.39	0.54	0.63	0.65	2.60	2.35	3.35	2.11	2.20	1.39	2.32	1.46	4.40	2.77	4.40	3.36	5.40	4.12			
	basic static load Coa	kN	0.77	0.75	1.34	0.92	3.64	3.30	5.90	2.95	3.50	1.75	4.05	2.02	7.90	3.95	7.90	5.27	10.5	7.00				
	part number	—	AC4-12DF	AC5-14DF	AC6-16DF	70M8DF/GMP5	7001T2DF/GMP5	7002T2DF/GMP5																
basic dynamic load Cb	kN	1.21	1.31	1.79	4.40	6.77	7.74																	
	basic static load Cob	kN	1.08	1.25	1.76	4.36	7.45	9.50																

*Please consult with NB when using BG15, BG20 and BG26 series in the Precision grade with short and frequent stroke. (short stroke: BG1501= 2mm or less, BG1502= 4mm or less, BG2001= 7mm or less, BG2005= 25mm or less, BG2602= 14mm or less and BG2605= 25mm or less)
 * M_{2P}, M_{2Y} and M_{2R} are the allowable static moments when 2 blocks are used in close contact.
 * Short blocks are not available for BG3320.

Figure G-8 Direction of Moment

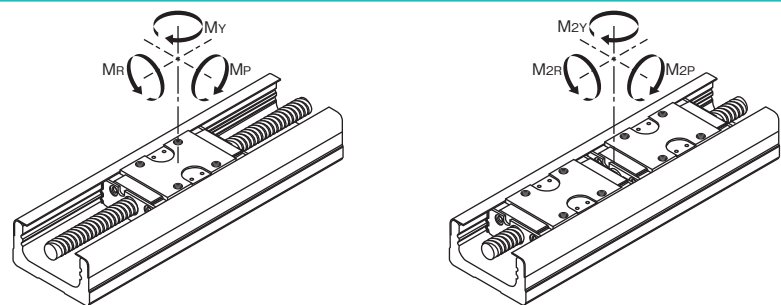

G-12

ALLOWABLE SPEED AND STROKE LIMIT

Allowable speed of BG type is subject to the type of motor and operating conditions. The speed may also be limited by the critical speed of the ball screw. Use caution when operating at high speeds or using long rails.

Table G-11 Allowable Speed and Stroke Limit

part number	rail length	stroke limit (mm)				allowable speed (mm/sec)		
		1 long block	2 long blocks	1 short block	2 short blocks	lead1	lead2	
BG15	75	30	—	—	—	185	370	
	100	55	—	—	—			
	125	80	46	—	—			
	150	105	71	—	—			
	175	130	96	—	—			
	200	155	121	—	—			
BG20	100	43	—	—	—	187	925	
	150	93	51	—	—			
	200	143	101	—	—			
	stroke limit (mm)	1 long block	2 long blocks	1 short block	2 short blocks			lead2
BG26	150	73	—	—	—	281	694	
	200	123	61	—	—			
	250	173	111	—	—			
	300	223	161	—	—			
BG33	150	60	—	85	34	550	1,100	1,500
	200	110	—	135	84			
	300	210	133	235	184			
	400	310	233	335	284			
	500	410	333	435	384			
	600	510	433	535	484			
	stroke limit (mm)	1 long block	2 long blocks	1 short block	2 short blocks			
BG46	340	209	100	245	172	740	1,480	
	440	309	200	345	272			
	540	409	300	445	372			
	640	509	400	545	472			
	740	609	500	645	572			
	840	709	600	745	672			
	940	809	700	845	772			
	1,040	909	800	945	872			
	1,140	1,009	900	1,045	972			
	1,240	1,109	1,000	1,145	1,072			
	BG55	980	834	711	—			—
1,080		934	811	—	—			
1,180		1,034	911	—	—			
1,280		1,134	1,011	—	—			
1,380		1,234	1,111	—	—			
stroke limit (mm)		1 long block	2 long blocks	1 short block	2 short blocks	lead20		

Short block type is not available for lead 20.

Figure G-9 Guide Rail Length and Allowable Speed

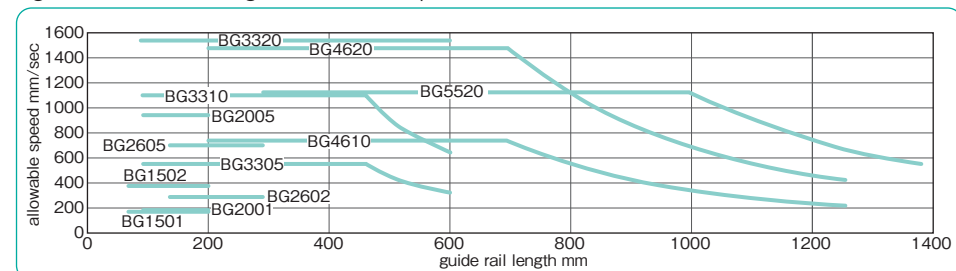

G-13

ACCURACY

Table G-12 shows accuracy of BG type.

Table G-12 Accuracy

part number	rail length mm	positioning repeatability		positioning accuracy		running parallelism B		backlash		*starting torque		
		high μm	precision μm	high μm	precision μm	high μm	precision μm	high μm	precision μm	high N·m	precision N·m	
BG15	75	± 3	± 1	40	20	20	10	5	2	0.01	0.012	
	100											
	125											
	150											
	175											
200												
BG20	100	± 3	± 1	50	20	25	10	5	2	0.01	0.012	
	150											
	200											
BG26	150	± 3	± 1	50	20	25	10	5	2	0.015	0.04	
	200											
	250											
	300											
BG33	150	± 3 (± 5)	± 1 (± 3)	30	15	25	10	5	2	0.07	0.15	
	200											
	300			35	20							
	400			40	25							15
	500			70	—							35
600	—	—	—	—	—	—	—	—	—	—		
BG46	340	± 3 (± 5)	± 1 (± 3)	35	20	35	15	5	2	0.10	0.15	
	440											
	540											
	640			40	25							
	740			50	30	40	20					
	840			80	—	50	—					
	940			—	—	—	—					
	1,040			—	—	—	—					
	1,140			—	—	—	—					
1,240	—	—	—	—								
BG55	980	± 3	± 1	80	35	50	25	5	2	0.12	0.17	
	1,080											
	1,180			40	30							
	1,280			100	—	—						
	1,380			—	—	—	—					

Above values are measured by using our selected motors.
 *Above specifications are based on using NB standard grease. Other grease may cause deviations.
 The values in the parentheses are positioning repeatability when used with return pulley unit.

Positioning Repeatability

After setting an arbitrary position, from one end, move the drive block to this position and measure the stop position. Repeat the positioning and measurement process 7 times with respect to the setting position at the midpoint and near both ends of travel. Take the maximum difference and divide it by 2, then indicate it with a positive and negative sign as the test result.

$$\text{positioning repeatability} = \pm \frac{1}{2} (\text{maximum value of } \ell_n - \text{minimum value of } \ell_n)$$

Positioning Accuracy

Positioning is performed in one direction and the resulting position is set as the datum point. Take the difference between the actual travel distance and the commanded travel distance from the datum point. Continuing in the same direction (without returning to the start point) repeat this process randomly several times until nearing to the stroke limit. Express the accuracy by the absolute maximum difference.

$$\text{positioning accuracy} = (\Delta \ell_n)_{\text{max}}$$

Running Parallelism B

After fixing the guide rail onto the surface plate, placing the dial test indicator on the center of the slide block and connecting the indicator probe onto the mounting surface, run the block over the entire travel distance. Take the maximum deviation in readings as the test result.

Backlash

Using the feed screw to move the slide block a little, take the dial test indicator reading and make it the datum point. While in this position, thrust the block by a certain force in the same direction without using the feed screw. Release the thrust and read the return, then take the difference from the datum point. Repeat the same process at the midpoint and near both ends of travel. Take the maximum difference as the test result.

$$\text{Backlash} = \Delta \ell$$

Figure G-10 Positioning Repeatability

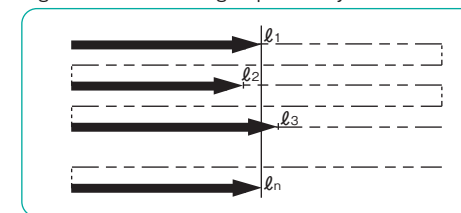

Figure G-11 Positioning Accuracy

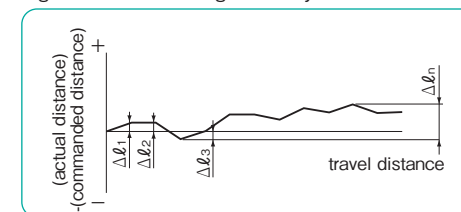

Figure G-12 Running Parallelism B

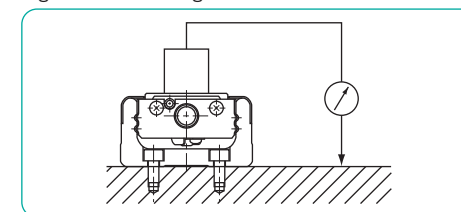
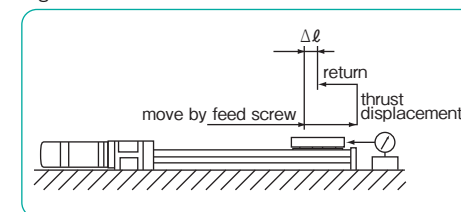
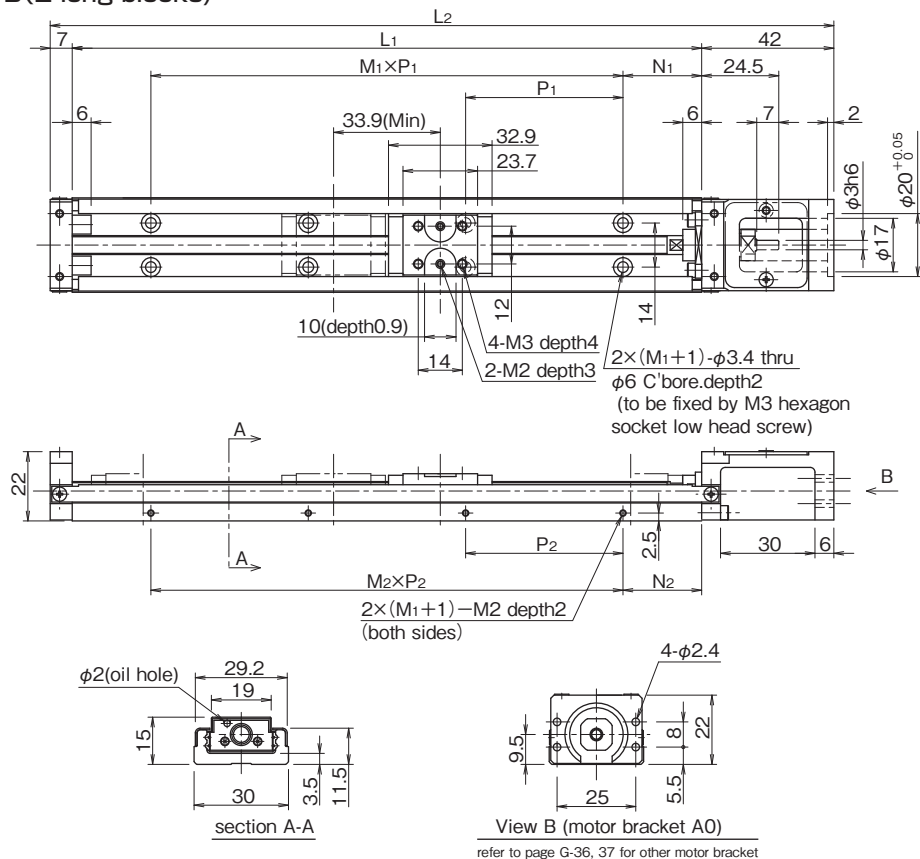

Figure G-13 Backlash



BG15 –Without Top Cover–

A(1 long block)
B(2 long blocks)



BG15 –With Top Cover–

A(1 long block)
B(2 long blocks)

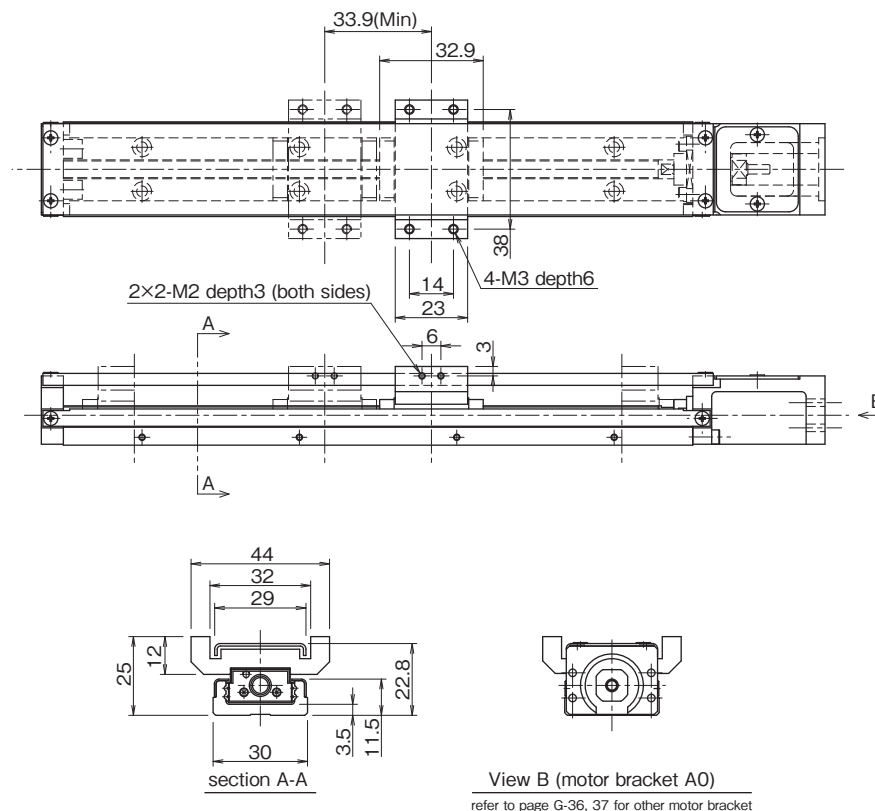

part number ^{3,4}	stroke limit mm ^{*1}	dimensions mm						block mass kg ^{*2}		total mass kg	
		L ₁	L ₂	N ₁	M ₁ ×P ₁	N ₂	M ₂ ×P ₂	without top cover	with top cover	without top cover	with top cover
BG15□□ A- 75	30	75	124	12.5	1×50	12.5	1×50	0.03	0.05	0.21	0.24
B	—	—	—	—	—	—	—	—	—	—	—
BG15□□ A-100	55	100	149	25	1×50	25	1×50	0.03	0.05	0.25	0.28
B	—	—	—	—	—	—	—	—	—	—	—
BG15□□ A-125	80	125	174	12.5	2×50	12.5	2×50	0.03	0.05	0.28	0.31
B	46	—	—	—				—	—	0.06	0.10
BG15□□ A-150	105	150	199	25	3×50	25	3×50	0.03	0.05	0.32	0.35
B	71	—	—	—				—	—	0.06	0.10
BG15□□ A-175	130	175	224	12.5	3×50	12.5	3×50	0.03	0.05	0.35	0.39
B	96	—	—	—				—	—	0.06	0.10
BG15□□ A-200	155	200	249	25	3×50	25	3×50	0.03	0.05	0.39	0.42
B	121	—	—	—				—	—	0.06	0.10

*1: Stroke limit is a drive distance between both ends of the dampers.

*2: Mass stated "with top cover" includes mass of sub tables.

*3: For B type (2 long blocks), drive block is located closest to motor bracket side.

*4: □ is ballscrew lead.

inertia (reference values)

unit:kg · m²

part number	rail length mm	long block			
		without top cover		with top cover	
		A 1 block	B 2 blocks	A 1 block	B 2 blocks
BG1501	75	1.06×10 ⁻⁷	—	1.07×10 ⁻⁷	—
	100	1.31×10 ⁻⁷	—	1.31×10 ⁻⁷	—
	125	1.56×10 ⁻⁷	1.56×10 ⁻⁷	1.56×10 ⁻⁷	1.58×10 ⁻⁷
	150	1.80×10 ⁻⁷	1.81×10 ⁻⁷	1.81×10 ⁻⁷	1.82×10 ⁻⁷
	175	2.05×10 ⁻⁷	2.06×10 ⁻⁷	2.06×10 ⁻⁷	2.07×10 ⁻⁷
BG1502	200	2.30×10 ⁻⁷	2.31×10 ⁻⁷	2.31×10 ⁻⁷	2.32×10 ⁻⁷
	75	1.09×10 ⁻⁷	—	1.11×10 ⁻⁷	—
	100	1.33×10 ⁻⁷	—	1.35×10 ⁻⁷	—
	125	1.58×10 ⁻⁷	1.62×10 ⁻⁷	1.60×10 ⁻⁷	1.66×10 ⁻⁷
	150	1.83×10 ⁻⁷	1.86×10 ⁻⁷	1.85×10 ⁻⁷	1.90×10 ⁻⁷
	175	2.08×10 ⁻⁷	2.11×10 ⁻⁷	2.10×10 ⁻⁷	2.15×10 ⁻⁷
	200	2.33×10 ⁻⁷	2.36×10 ⁻⁷	2.35×10 ⁻⁷	2.40×10 ⁻⁷

Key components and materials

part name	material	remarks
guide rail	stainless steel	
ballscrew shaft	steel	
slide block	steel	
motor bracket	aluminum alloy	white anodizing
housing	aluminum alloy	white anodizing
adapter plate	aluminum alloy	white anodizing
dust cover	aluminum alloy	white anodizing
sub table	aluminum alloy	white anodizing
top cover	aluminum alloy	white anodizing

When LB option is selected, steel parts are treated with low temperature black chrome treatment. Black chrome treatment is applied to the slide block only.

BG20 –Without Top Cover–

A(1 long block)
B(2 long blocks)

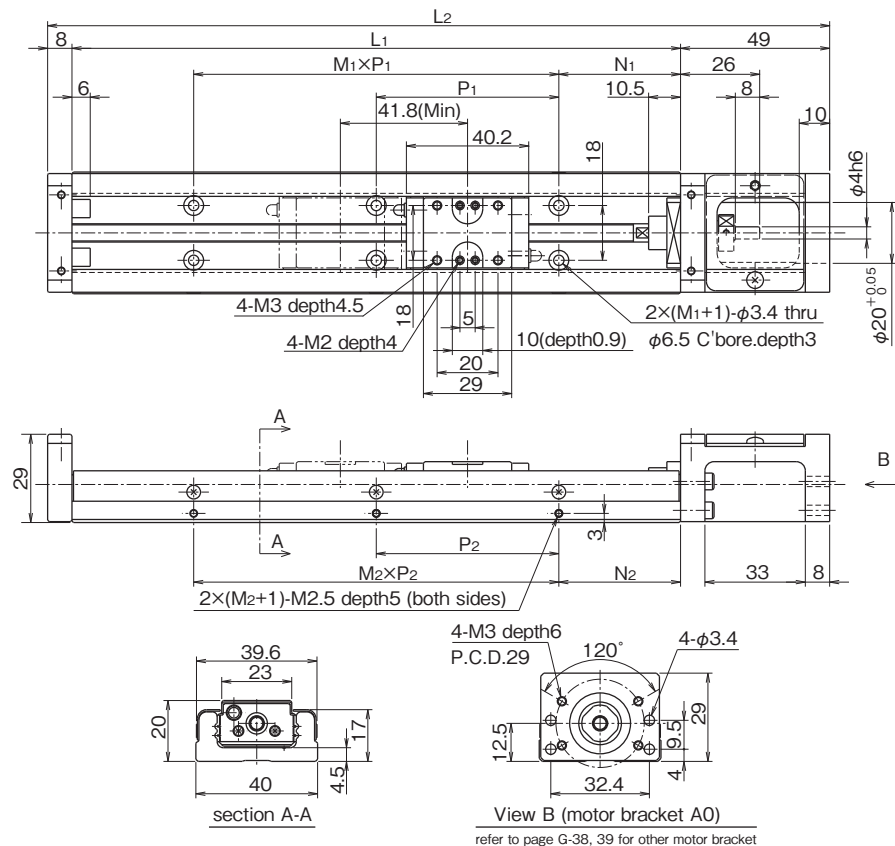

BG20 –With Top Cover–

A(1 long block)
B(2 long blocks)

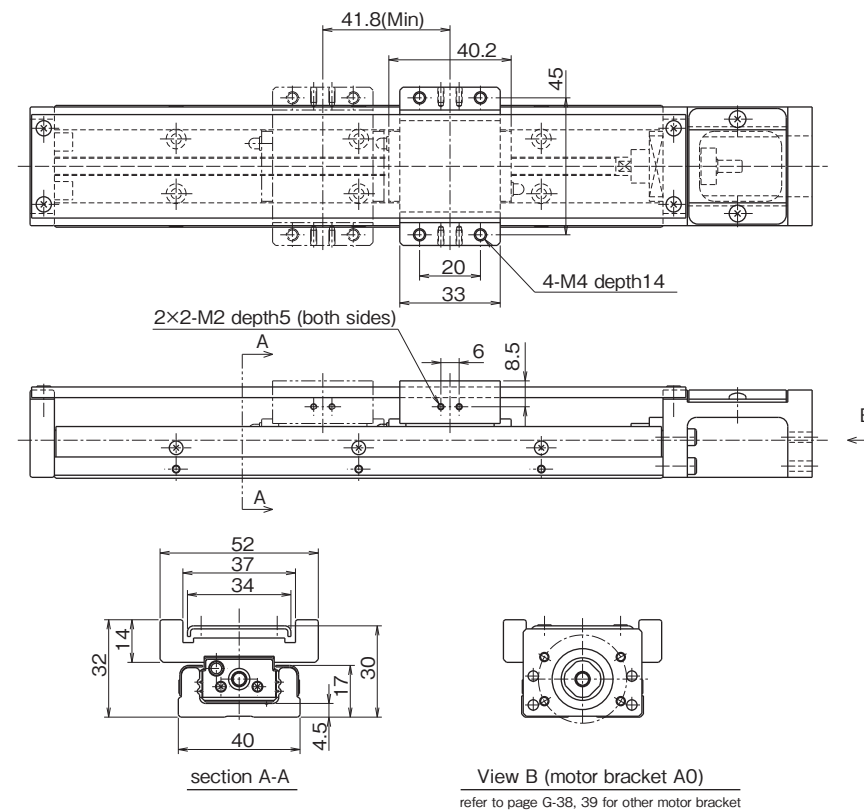

part number ^{*3,4}	stroke limit mm ^{*1}	dimensions mm		dimensions mm			block mass kg ^{*2}		total mass kg		
		L ₁	L ₂	N ₁	M ₁ ×P ₁	N ₂	M ₂ ×P ₂	without top cover	with top cover	without top cover	with top cover
BG20□□A-100	43	100	157	20	1×60	20	1×60	0.07	0.11	0.45	0.50
B	—	—	—	—	—	—	—	—	—	—	—
BG20□□A-150	93	150	207	15	2×60	15	2×60	0.07	0.11	0.58	0.63
B	51	—	—	—				—	—	0.14	0.22
BG20□□A-200	143	200	257	40	—	40	—	0.07	0.11	0.71	0.77
B	101	—	—	—	—	—	—	0.14	0.22	0.78	0.88

*1: Stroke limit is a drive distance between both ends of the dampers.
*2: Mass stated "with top cover" includes mass of sub tables.
*3: For B type (2 long blocks), drive block is located closest to motor bracket side.
*4: □ is ballscrew lead.

inertia (reference values)

unit:kg · m²

part number	rail length mm	long block			
		without top cover		with top cover	
		A	B	A	B
BG2001	100	1.34×10 ⁻⁷	—	1.35×10 ⁻⁷	—
	150	1.83×10 ⁻⁷	1.85×10 ⁻⁷	1.84×10 ⁻⁷	1.87×10 ⁻⁷
	200	2.33×10 ⁻⁷	2.35×10 ⁻⁷	2.34×10 ⁻⁷	2.37×10 ⁻⁷
BG2005	100	1.76×10 ⁻⁷	—	2.00×10 ⁻⁷	—
	150	2.26×10 ⁻⁷	2.70×10 ⁻⁷	2.50×10 ⁻⁷	3.18×10 ⁻⁷
	200	2.76×10 ⁻⁷	3.20×10 ⁻⁷	3.00×10 ⁻⁷	3.68×10 ⁻⁷

Key components and materials

part name	material	remarks
guide rail	stainless steel	
ballscrew shaft	steel	
slide block	steel	
motor bracket:A0	aluminum die cast	baking acrylic painting: silvery-white color
motor bracket: R0	aluminum alloy	white anodizing
housing	aluminum alloy	white anodizing
adapter plate	aluminum alloy	white anodizing
dust cover	aluminum alloy	white anodizing
sub table	aluminum alloy	white anodizing
top cover	aluminum alloy	white anodizing

When LB option is selected, steel parts are treated with low temperature black chrome treatment.

BG33 –Without Top Cover–

A(1 long block)
B(2 long blocks)

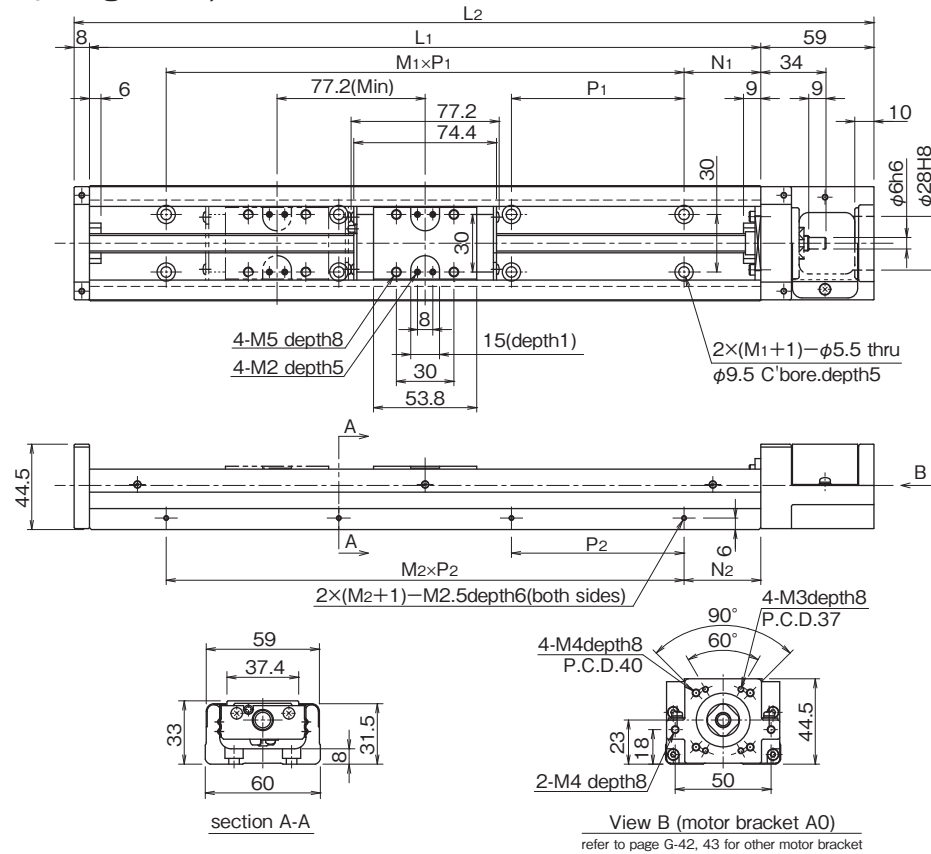

View B (motor bracket A0)
refer to page G-42, 43 for other motor bracket

part number ^{*3,4}	stroke limit mm ^{*1}	dimensions mm					block mass kg ^{*2}		total mass kg		
		L ₁	L ₂	N ₁	M ₁ ×P ₁	N ₂	M ₂ ×P ₂	without top cover	with top cover	without top cover	with top cover
BG33□□A-150	60	150	217	25	1×100	25	1×100	0.3	0.4	1.6	1.8
B	—	—	—	—	—	—	—	—	—	—	—
BG33□□A-200	110	200	267	50	1×100	50	1×100	0.3	0.4	2	2.1
B	—	—	—	—	—	—	—	—	—	—	—
BG33□□A-300	210	300	367	50	2×100	50	2×100	0.3	0.4	2.6	2.8
B	133	—	—					0.6	0.8	2.9	3.2
BG33□□A-400	310	400	467	50	3×100	50	3×100	0.3	0.4	3.2	3.5
B	233							0.6	0.8	3.6	3.9
BG33□□A-500	410	500	567	50	4×100	50	4×100	0.3	0.4	3.9	4.2
B	333							0.6	0.8	4.2	4.6
BG33□□A-600	510	600	667	50	5×100	50	5×100	0.3	0.4	4.6	4.9
B	433							0.6	0.8	4.9	5.3

*1: Stroke limit is a drive distance between both ends of the dampers.
*2: Mass stated "with top cover" includes mass of sub tables.
*3: For B type (2 long blocks), drive block is located closest to motor bracket side.
*4: □ is ballscrew lead.

BG33 –With Top Cover–

A(1 long block)
B(2 long blocks)

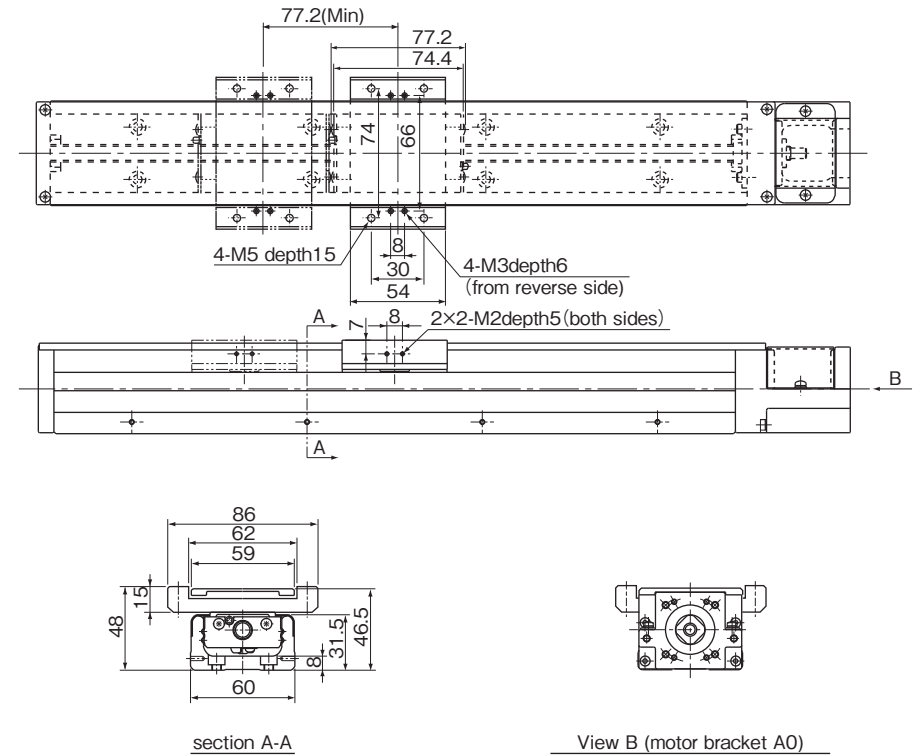

View B (motor bracket A0)
refer to page G-42, 43 for other motor bracket

inertia (reference values)

part number	rail length mm	long block				unit:kg·m ²	
		without top cover		with top cover		A	B
		A	B	A	B		
BG3305	150	1.64×10 ⁻⁶	—	1.71×10 ⁻⁶	—	—	—
	200	2.02×10 ⁻⁶	—	2.09×10 ⁻⁶	—		
	300	2.79×10 ⁻⁶	2.99×10 ⁻⁶	2.86×10 ⁻⁶	3.13×10 ⁻⁶		
	400	3.55×10 ⁻⁶	3.75×10 ⁻⁶	3.62×10 ⁻⁶	3.89×10 ⁻⁶		
	500	4.32×10 ⁻⁶	4.52×10 ⁻⁶	4.39×10 ⁻⁶	4.66×10 ⁻⁶		
	600	5.08×10 ⁻⁶	5.28×10 ⁻⁶	5.15×10 ⁻⁶	5.42×10 ⁻⁶		
BG3310	150	2.19×10 ⁻⁶	—	2.47×10 ⁻⁶	—	—	—
	200	2.57×10 ⁻⁶	—	2.85×10 ⁻⁶	—		
	300	3.34×10 ⁻⁶	4.14×10 ⁻⁶	3.61×10 ⁻⁶	4.69×10 ⁻⁶		
	400	4.10×10 ⁻⁶	4.90×10 ⁻⁶	4.38×10 ⁻⁶	5.46×10 ⁻⁶		
	500	4.87×10 ⁻⁶	5.67×10 ⁻⁶	5.15×10 ⁻⁶	6.22×10 ⁻⁶		
	600	5.63×10 ⁻⁶	6.43×10 ⁻⁶	5.91×10 ⁻⁶	6.99×10 ⁻⁶		
BG3320	150	5.94×10 ⁻⁶	—	7.06×10 ⁻⁶	—	—	—
	200	6.74×10 ⁻⁶	—	7.85×10 ⁻⁶	—		
	300	8.33×10 ⁻⁶	1.15×10 ⁻⁵	9.44×10 ⁻⁶	1.38×10 ⁻⁵		
	400	9.91×10 ⁻⁶	1.31×10 ⁻⁵	1.10×10 ⁻⁵	1.53×10 ⁻⁵		
	500	1.15×10 ⁻⁵	1.47×10 ⁻⁵	1.26×10 ⁻⁵	1.69×10 ⁻⁵		
	600	1.31×10 ⁻⁵	1.63×10 ⁻⁵	1.42×10 ⁻⁵	1.85×10 ⁻⁵		

Key components and materials		
part name	material	remarks
guide rail	steel	black oxide except for grinding processing part
ballscrew shaft	steel	
slide block	steel	
motor bracket: A0	aluminum die cast	baking acrylic painting: silvery-white color
motor bracket: R0	aluminum alloy	white anodizing
housing	aluminum die cast	baking acrylic painting: silvery-white color
low housing	aluminum alloy	white anodizing
adapter plate	steel	black oxide
dust cover	aluminum alloy	white anodizing
sub table	aluminum alloy	white anodizing
top cover	aluminum alloy	white anodizing

When LB option is selected, steel parts are treated with low temperature black chrome treatment.

BG33 –Without Top Cover–

C(1 short block)
D(2 short blocks)

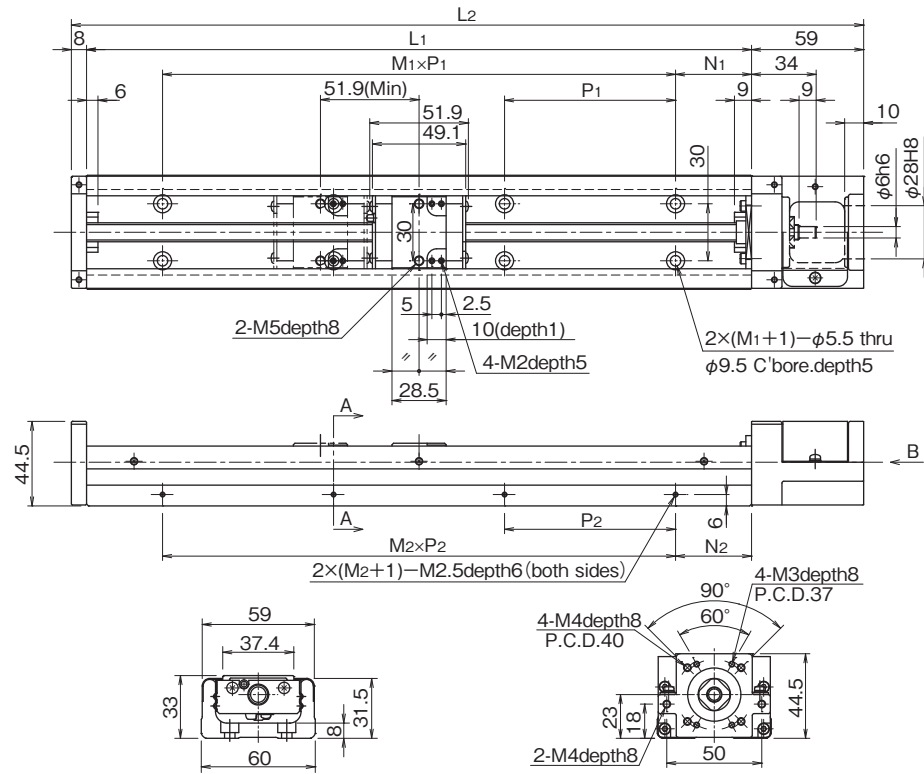

section A-A

View B (motor bracket A0)
refer to page G-42, 43 for other motor bracket

BG33 –With Top Cover–

C(1 short block)
D(2 short blocks)

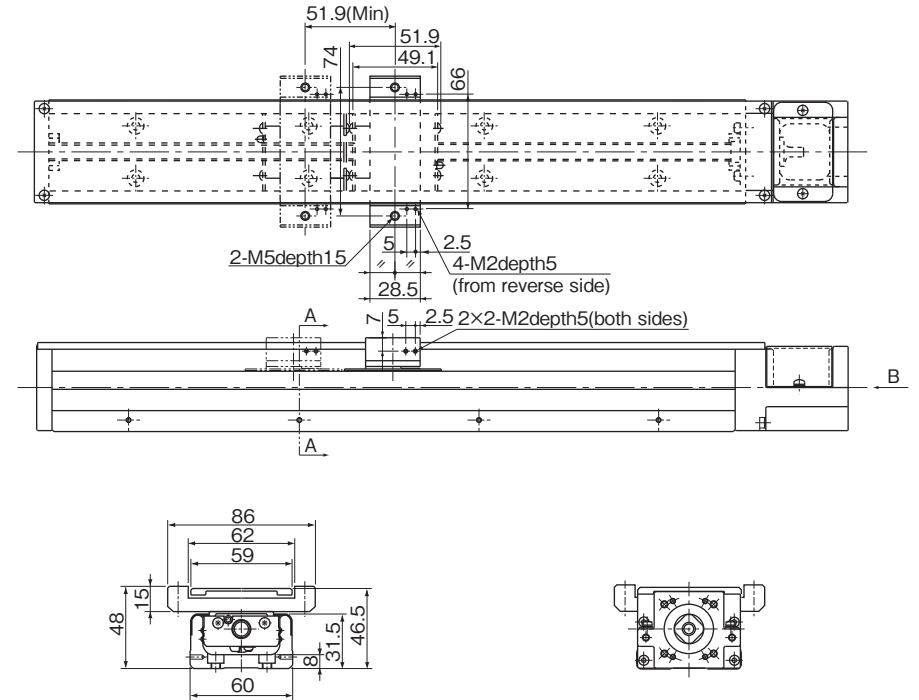

section A-A

View B (motor bracket A0)
refer to page G-42,43 for other motor bracket

part number ^{3,4}	stroke limit mm ¹	dimensions mm					block mass kg ²		total mass kg		
		L ₁	L ₂	N ₁	M ₁ ×P ₁	N ₂	M ₂ ×P ₂	without top cover	with top cover	without top cover	with top cover
BG33□□C-150	85	150	217	25	1×100	25	1×100	0.15	0.2	1.5	1.6
	34							0.3	0.4	1.7	1.9
BG33□□C-200	135	200	267	50	3×100	50	3×100	0.15	0.2	1.8	2
	84							0.3	0.4	2	2.2
BG33□□C-300	235	300	367	50	3×100	50	3×100	0.15	0.2	2.5	2.6
	184							0.3	0.4	2.7	2.9
BG33□□C-400	335	400	467	50	3×100	50	3×100	0.15	0.2	3.1	3.3
	284							0.3	0.4	3.3	3.5
BG33□□C-500	435	500	567	50	4×100	50	4×100	0.15	0.2	3.8	4
	384							0.3	0.4	3.9	4.2
BG33□□C-600	535	600	667	50	5×100	50	5×100	0.15	0.2	4.4	4.7
	484							0.3	0.4	4.6	4.9

*1: Stroke limit is a drive distance between both ends of the dampers.
*2: Mass stated "with top cover" includes mass of sub tables.
*3: For D type (2 short blocks), drive block is located closest to motor bracket side.
*4: □ is ballscrew lead.
*5: Ballscrew lead of 20mm is not available for BG33 short block type.

inertia (reference values)

unit:kg · m²

part number	rail length mm	short block			
		without top cover		with top cover	
		C	D	C	D
BG3305	150	1.56×10 ⁻⁶	1.64×10 ⁻⁶	1.60×10 ⁻⁶	1.71×10 ⁻⁶
	200	1.94×10 ⁻⁶	2.03×10 ⁻⁶	1.98×10 ⁻⁶	2.10×10 ⁻⁶
	300	2.71×10 ⁻⁶	2.79×10 ⁻⁶	2.75×10 ⁻⁶	2.86×10 ⁻⁶
	400	3.48×10 ⁻⁶	3.56×10 ⁻⁶	3.51×10 ⁻⁶	3.63×10 ⁻⁶
	500	4.24×10 ⁻⁶	4.32×10 ⁻⁶	4.28×10 ⁻⁶	4.39×10 ⁻⁶
BG3310	150	1.88×10 ⁻⁶	2.21×10 ⁻⁶	2.02×10 ⁻⁶	2.49×10 ⁻⁶
	200	2.27×10 ⁻⁶	2.59×10 ⁻⁶	2.40×10 ⁻⁶	2.87×10 ⁻⁶
	300	3.03×10 ⁻⁶	3.36×10 ⁻⁶	3.17×10 ⁻⁶	3.64×10 ⁻⁶
	400	3.80×10 ⁻⁶	4.12×10 ⁻⁶	3.94×10 ⁻⁶	4.40×10 ⁻⁶
	500	4.56×10 ⁻⁶	4.89×10 ⁻⁶	4.70×10 ⁻⁶	5.17×10 ⁻⁶
600	5.33×10 ⁻⁶	5.65×10 ⁻⁶	5.47×10 ⁻⁶	5.93×10 ⁻⁶	

Key components and materials

part name	material	remarks
guide rail	steel	black oxide except for grinding processing part
ballscrew shaft	steel	
slide block	steel	
motor bracket: A0	aluminum die cast	baking acrylic painting: silvery-white color
motor bracket: R0	aluminum alloy	white anodizing
housing	aluminum die cast	baking acrylic painting: silvery-white color
low housing	aluminum alloy	white anodizing
adapter plate	steel	black oxide
dust cover	aluminum alloy	white anodizing
sub table	aluminum alloy	white anodizing
top cover	aluminum alloy	white anodizing

When LB option is selected, steel parts are treated with low temperature black chrome treatment.

BG46 –Without Top Cover–

A(1 long block)
B(2 long blocks)

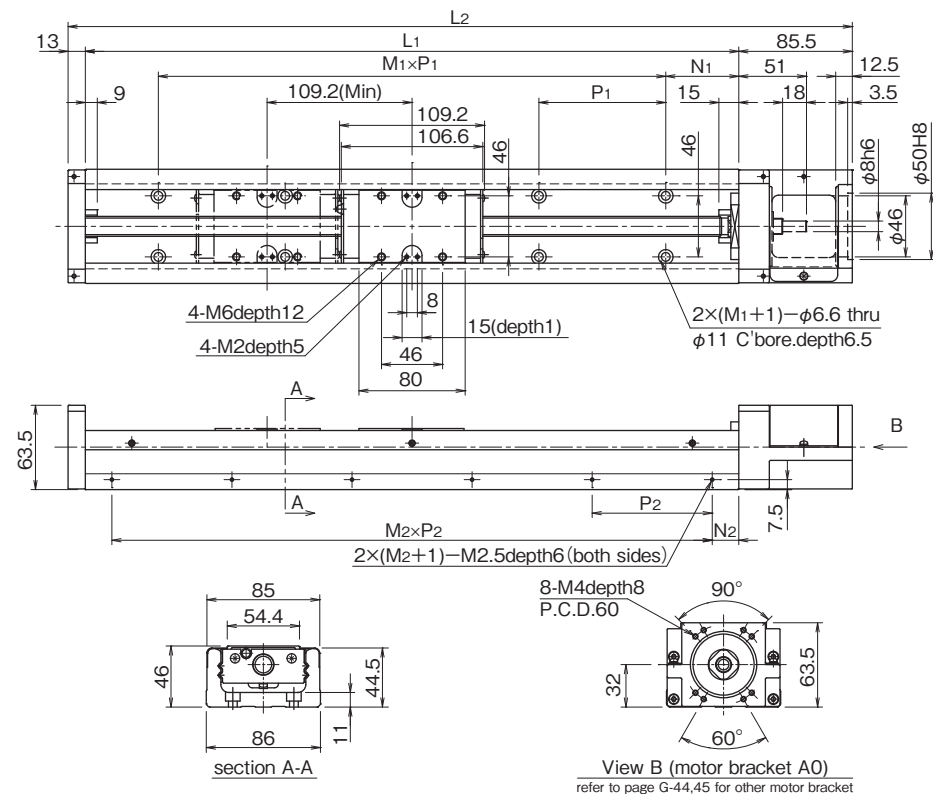

BG46 –With Top Cover–

A(1 long block)
B(2 long blocks)

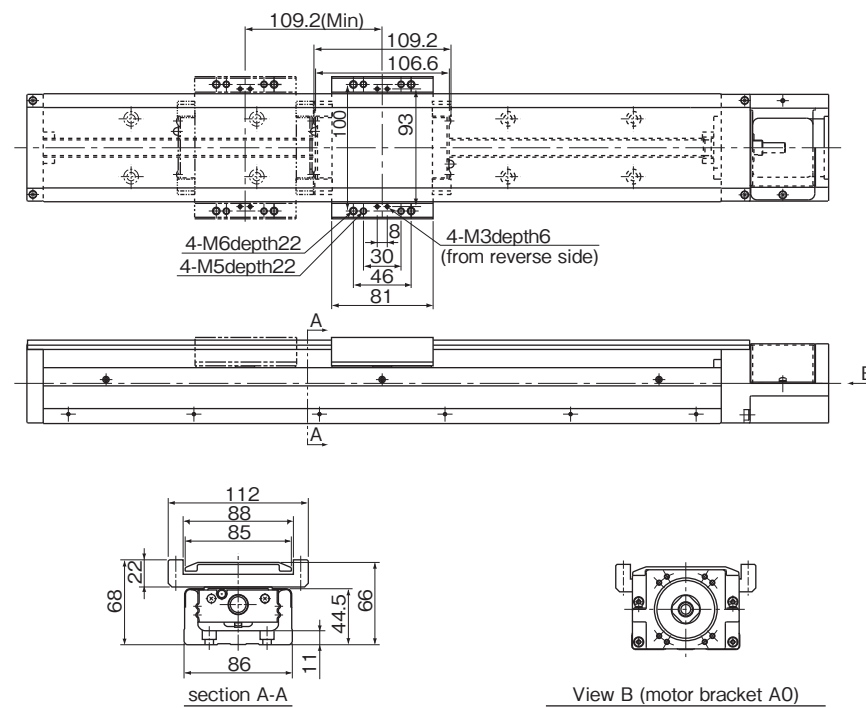

part number ^{3,4}	stroke limit mm ¹	dimensions mm		block mass kg ²		total mass kg					
		L ₁	L ₂	without top cover	with top cover	without top cover	with top cover				
BG46□□A-340	209	340	438.5	70	20	2×100	3×100	0.9	1.2	6.5	7
	B							100	1.8	2.4	7.5
BG46□□A-440	309	440	538.5			3×100	4×100	0.9	1.2	8	8.5
	B							200	1.8	2.4	8.5
BG46□□A-540	409	540	638.5			4×100	5×100	0.9	1.2	9	10
	B							300	1.8	2.4	10
BG46□□A-640	509	640	738.5			5×100	6×100	0.9	1.2	10.5	11
	B							400	1.8	2.4	11.5
BG46□□A-740	609	740	838.5			6×100	7×100	0.9	1.2	12	12.5
	B							500	1.8	2.4	13
BG46□□A-840	709	840	938.5			7×100	8×100	0.9	1.2	13	14
	B							600	1.8	2.4	14
BG46□□A-940	809	940	1,038.5	8×100	9×100	0.9	1.2	14.5	15.5		
	B					700	1.8	2.4	15.5	16.5	
BG46□□A-1040	909	1,040	1,138.5	9×100	10×100	0.9	1.2	16	17		
	B					800	1.8	2.4	17	18	
BG46□□A-1140	1,009	1,140	1,238.5	10×100	11×100	0.9	1.2	17.5	18.5		
	B					900	1.8	2.4	18	19.5	
BG46□□A-1240	1,109	1,240	1,338.5	11×100	12×100	0.9	1.2	18.5	19.5		
	B					1,000	1.8	2.4	19.5	21	

*1: Stroke limit is a drive distance between both ends of the dampers.
 *2: Mass stated "with top cover" includes mass of sub tables.
 *3: For B type (2 long blocks), drive block is located closest to motor bracket side.
 *4: □ is ballscrew lead.

inertia (reference values) unit: kg · m² refer to page G-44.45 for other motor bracket

part number	rail length mm	long block				
		without top cover		with top cover		
		A	B	A	B	
BG4610	340	1.79×10 ⁻⁵	2.02×10 ⁻⁵	1.87×10 ⁻⁵	2.17×10 ⁻⁵	
	440	2.18×10 ⁻⁵	2.41×10 ⁻⁵	2.25×10 ⁻⁵	2.56×10 ⁻⁵	
	540	2.57×10 ⁻⁵	2.79×10 ⁻⁵	2.64×10 ⁻⁵	2.95×10 ⁻⁵	
	640	2.95×10 ⁻⁵	3.18×10 ⁻⁵	3.03×10 ⁻⁵	3.33×10 ⁻⁵	
	740	3.34×10 ⁻⁵	3.57×10 ⁻⁵	3.42×10 ⁻⁵	3.72×10 ⁻⁵	
	840	3.73×10 ⁻⁵	3.96×10 ⁻⁵	3.80×10 ⁻⁵	4.11×10 ⁻⁵	
	940	4.12×10 ⁻⁵	4.35×10 ⁻⁵	4.19×10 ⁻⁵	4.50×10 ⁻⁵	
	1,040	4.50×10 ⁻⁵	4.74×10 ⁻⁵	4.58×10 ⁻⁵	4.88×10 ⁻⁵	
	1,140	4.89×10 ⁻⁵	5.12×10 ⁻⁵	4.97×10 ⁻⁵	5.27×10 ⁻⁵	
	1,240	5.28×10 ⁻⁵	5.51×10 ⁻⁵	5.35×10 ⁻⁵	5.66×10 ⁻⁵	
	BG4620	340	2.47×10 ⁻⁵	3.39×10 ⁻⁵	2.78×10 ⁻⁵	3.99×10 ⁻⁵
		440	2.86×10 ⁻⁵	3.77×10 ⁻⁵	3.17×10 ⁻⁵	4.38×10 ⁻⁵
540		3.25×10 ⁻⁵	4.16×10 ⁻⁵	3.55×10 ⁻⁵	4.77×10 ⁻⁵	
640		3.63×10 ⁻⁵	4.55×10 ⁻⁵	3.94×10 ⁻⁵	5.16×10 ⁻⁵	
740		4.03×10 ⁻⁵	4.94×10 ⁻⁵	4.33×10 ⁻⁵	5.55×10 ⁻⁵	
840		4.41×10 ⁻⁵	5.34×10 ⁻⁵	4.71×10 ⁻⁵	5.93×10 ⁻⁵	
940		4.80×10 ⁻⁵	5.72×10 ⁻⁵	5.09×10 ⁻⁵	6.32×10 ⁻⁵	
1,040		5.19×10 ⁻⁵	6.11×10 ⁻⁵	5.48×10 ⁻⁵	6.71×10 ⁻⁵	
1,140		5.57×10 ⁻⁵	6.50×10 ⁻⁵	5.87×10 ⁻⁵	7.09×10 ⁻⁵	
1,240		5.96×10 ⁻⁵	6.89×10 ⁻⁵	6.26×10 ⁻⁵	7.48×10 ⁻⁵	

Key components and materials		
part name	material	remarks
guide rail	steel	black oxide except for grinding processing part
ballscrew shaft	steel	
slide block	steel	
motor bracket:A0	aluminum die cast	baking acrylic painting: silvery-white color
motor bracket:B0	aluminum die cast	baking acrylic painting: silvery-white color
motor bracket:C0	aluminum die cast	baking acrylic painting: silvery-white color
motor bracket:D0	aluminum die cast	baking acrylic painting: silvery-white color
motor bracket:R0	aluminum alloy	white anodizing
housing	aluminum die cast	baking acrylic painting: silvery-white color
low housing	aluminum alloy	white anodizing
adapter plate	steel	black oxide
dust cover	aluminum alloy	white anodizing
sub table	aluminum alloy	white anodizing
top cover	aluminum alloy	white anodizing

When LB option is selected, steel parts are treated with low temperature black chrome treatment.

MOTOR BRACKET CONFIGURATIONS & APPLICABLE MOTORS

NB provides optional motor brackets and adapter plates to easily install most popular motors.

Table G-13 (1) Applicable Motors

Applicable motors			Output	BG15	BG20	BG26	BG33	BG46	BG55		
				P.G-36 ~37	P.G-38 ~39	P.G-40 ~41	P.G-42 ~43	P.G-44 ~45	P.G-46 ~47		
AC Servo motor	Panasonic	E	MUMA5A	50W	-	AA	AA	B2	-	-	
			MUMA01	100W	-	AA	AA	B2	-		
			MUMA02	200W	-	-	-	A7	A2		-
			MUMA04	400W	-	-	-	-	-		-
		A5	MSME5A	50W	-	A3	A3	A2	C0	-	-
			MSME01	100W	-	-	-	A7	A2	-	
			MSME02	200W	-	-	-	-	-	-	
			MSME04	400W	-	-	-	-	A3	A2	
		A6	MSMF5A	50W	-	A3	A3	A2	C0	-	-
			MSMF01	100W	-	-	-	-	-	-	
			MSMF02	200W	-	-	-	A7	A2	-	
			MSMF04	400W	-	-	-	-	-	-	
	MITSUBISHI ELECTRIC	J3	HF-KP(MP)053	50W	-	A1	A1	A1	B0	-	-
			HF-KP(MP)13	100W	-	-	-	-	-	-	
			HF-KP(MP)23	200W	-	-	-	A6	A1	A0	
			HF-KP(MP)43	400W	-	-	-	-	-	-	
		J4	HF-KP(MP)73	750W	-	-	-	-	A4	A1	-
			HG-AK0136	10W	-	-	-	-	-	-	
			HG-AK0236	20W	A2	A9	A9	-	-	-	
			HG-AK0336	30W	-	-	-	-	-	-	
			HG-KR(MR)053	50W	-	A1	A1	A1	B0	-	
			HG-KR(MR)13	100W	-	-	-	-	-	-	
			HG-KR(MR)23	200W	-	-	-	A6	A1	A0	
			HG-KR(MR)43	400W	-	-	-	-	-	-	
	YASKAWA ELECTRIC	Σ-V mini	SGMMV-A1	10W	-	-	-	-	-	-	-
			SGMMV-A2	20W	A2	A9	A9	-	-	-	
			SGMMV-A3	30W	-	-	-	-	-	-	
		Σ-V	SGMJV(SGMAV)-A5	50W	-	-	-	-	-	-	-
			SGMJV(SGMAV)-01	100W	-	A1	A1	A1	B0	-	
			SGMAV-C2	150W	-	-	-	-	-	-	
			SGMJV(SGMAV)-02	200W	-	-	-	A6	A1	A0	
			SGMJV(SGMAV)-04	400W	-	-	-	-	-	-	
			SGMAV-06	550W	-	-	-	-	-	-	
			SGMJV(SGMAV)-08	750W	-	-	-	-	A4	A1	
			Σ-7	SGM7J(SGM7A)-A5	50W	-	-	-	-	-	
		SGM7J(SGM7A)-01		100W	-	A1	A1	A1	B0	-	
SGM7J(SGM7A)-C2	150W	-		-	-	-	-	-			
SGM7J(SGM7A)-02	200W	-		-	-	A6	A1	A0			
SGM7J(SGM7A)-04	400W	-		-	-	-	-	-			
SGM7J(SGM7A)-06	600W	-		-	-	-	-	-			
SGM7J(SGM7A)-08	750W	-		-	-	-	A4	A1			

Table G-13 (2) Applicable Motors

Applicable motors			Output	BG15	BG20	BG26	BG33	BG46	BG55				
				P.G-36 ~37	P.G-38 ~39	P.G-40 ~41	P.G-42 ~43	P.G-44 ~45	P.G-46 ~47				
AC Servo motor	SANYO DENKI	Q	Q1AA04003D	30W	-	-	-	-	-	-			
			Q1AA04005D	50W	-	A1	A1	A1	B0				
			Q1AA04010D	100W	-	-	-	-	-		-		
			Q1AA06020D	200W	-	-	-	A6	A1		A0		
			Q1AA06040D	400W	-	-	-	-	-		-		
			Q1AA07075D	750W	-	-	-	-	A4		A1		
		R	R2AA04005	50W	-	A1	A1	A1	B0	-	-		
			R2AA04010	100W	-	-	-	-	-	-			
			R2AA06020	200W	-	-	-	A6	A1	A0			
			R2AA06040	400W	-	-	-	-	-	-			
			R2AA08075	750W	-	-	-	-	A4	A1			
			G	R88M-G05030	50W	-	A1	A1	A1	B0		-	-
	R88M-G10030	100W		-	-	-	-	-	-				
	R88M-G20030	200W		-	-	-	A7	A2	-				
	R88M-G40030	400W		-	-	-	-	-	-				
	R88M-G75030	750W		-	-	-	-	A3	A2				
	G5	R88M-K05030		50W	-	A1	A1	A1	B0	-	-		
		R88M-K10030	100W	-	-	-	-	-	-				
		R88M-K20030	200W	-	-	-	A7	A2	-				
		R88M-K40030	400W	-	-	-	-	A3	A2				
		R88M-K75030	750W	-	-	-	-	-	-				
		1S	R88M-1M10030	100W	-	A1	A1	A1	B0	-		-	
	R88M-1M20030		200W	-	-	-	A7	A2	-				
	R88M-1M40030		400W	-	-	-	-	-	-				
	R88M-1M75030		750W	-	-	-	-	A3	A2				
	KEYENCE		MV	MV-M005	50W	-	A1	A1	A1	B0	-		-
				MV-M010	100W	-	-	-	-	-			
		MV-M020		200W	-	-	-	A6	A1	A0			
		SV	MV-M040	400W	-	-	-	-	-	-			
			MV-M075	750W	-	-	-	-	A4	A1			
			SV(SV2)-M005	50W	-	A1	A1	A1	B0	-			
	SV(SV2)-M010	100W	-	-	-	-	-	-					
	SV(SV2)-M020	200W	-	-	-	A6	A1	A0					
	SV(SV2)-M040	400W	-	-	-	-	-	-					
	SV(SV2)-M075	750W	-	-	-	-	A4	A1					
	FANUC	βis	βis0.2/5000	50W	-	-	-	-	-	-			
			βis0.3/5000	100W	-	A1	A1	A1	B0				
			βis0.4/5000 ※	130W	-	-	-	A6	A1		A0		
			βis0.5/6000 ※	350W	-	-	-	-	-		-		
			βis1/6000	500W	-	-	-	-	-		-		

※ Please contact NB for the coupling because the motor shaft length will be shortened. NB can provide other types of motor brackets. Please contact NB for details.

MOTOR BRACKET CONFIGURATIONS & APPLICABLE MOTORS

Table G-14 (1) Applicable Motors

Applicable motors		Flange	BG15	BG20	BG26	BG33	BG46	BG55			
			P.G-36 ~37	P.G-38 ~39	P.G-40 ~41	P.G-42 ~43	P.G-44 ~45	P.G-46 ~47			
Stepper motor	ORIENTAL MOTOR	α step	AR	AR1	□20	A6	—	—	—	—	
				AR2	□28	A3	A6	A6	—	—	—
				AR46	□42	—	A5	A5	B1	—	—
				AR6	□60	—	—	—	A8	D0	—
				AR9	□85	—	—	—	—	D1	A4
		AZ	AZM1	□20	A6	—	—	—	—	—	
			AZM2	□28	A3	A6	A6	—	—	—	
			AZM4	□42	—	A5	A5	B1	—	—	
			AZM6	□60	—	—	—	A8	D0	—	
			AZM9	□85	—	—	—	—	D1	A4	
		5 phase motor	RK II	RKS54	□42	—	A5	A5	B1	—	—
				RKS56	□60	—	—	—	A8	D0	—
				RKS59	□85	—	—	—	—	D1	A4
			CRK	CRK51	□20	A5	—	—	—	—	—
				CRK52	□28	A3	A6	A6	—	—	—
	CRK54			□42	—	A5	A5	B1	—	—	
	CRK56			□60	—	—	—	A8	D0	—	
	CVK (PKP)		PK51	□20	A5	—	—	—	—	—	
			PKP52	□28	A3	A6	A6	—	—	—	
			PKP54	□42	—	A5	A5	B1	—	—	
		PKP56	□56.4	—	—	—	A5	—	—		
		PKP56□F	□60	—	—	—	A8	D0	—		
	2 phase motor	CVK (PKP)	PK59	□85	—	—	—	—	D1	A4	
			PKP21	□20	A6	—	—	—	—	—	
			PKP22	□28	A3	A6	A6	—	—	—	
			PKP24	□42	—	A5	A5	B1	—	—	
			PKP26	□56.4	—	—	—	A5	—	—	
	SANYO DENKI	5 phase motor	F5	SH528	□28	A3	A6	A6	—	—	
				SM542	□42	—	A5	A5	B1	—	
				SM560	□60	—	—	—	A8	D0	—
SM586				□85	—	—	—	—	D1	A5	
2 phase motor		F2	SH228	□28	A3	A6	A6	—	—		
			SH142,103H52	□42	—	A5	A5	B1	—		
			103H712	□56.4	—	—	—	A5	—		
		103H782(connector type)	□60	—	—	—	A8	D0			
TECHNO DRIVE	5 phase motor	□K-S51□	□20	A6	—	—	—	—			
		□K-S52□	□28	A4	—	—	—	—			
		□K-S54□	□42	—	A5	A5	B1	—			
		□K-S(M)56□	□60	—	—	—	A8	D0			
		□K-M(G)59□	□85	—	—	—	—	D1	A5		

NB can provide other types of motor brackets. Please contact NB for details.

Table G-14 (2) Applicable Motors

Applicable motors		Flange	BG15	BG20	BG26	BG33	BG46	BG55		
			P.G-36 ~37	P.G-38 ~39	P.G-40 ~41	P.G-42 ~43	P.G-44 ~45	P.G-46 ~47		
Stepper motor	TAMAGAWA SEIKI	2 phase motor	TS3692	□20	A6	—	—	—	—	
			TS3641	□28	A3	A6	A6	—	—	
			TS3617	□42	—	A5	A5	B1	—	
			TS3690	□56.4	—	—	—	A5	—	
			TS3682	□20	A6	—	—	—	—	
		5 phase motor	TS3667	□42	—	A5	A5	B1	—	
			TS3624*	□60	—	—	—	A8	D0	
			TS3630	□86	—	—	—	—	D1	A5
			TS3699N112	□28	A3	A6	A6	—	—	
			TS3699N172	□42	—	A5	A5	B1	—	
		TS3699N231(N232)	□56.4	—	—	—	A5	—		
Stepper servo	sammet electronics	Si servo	TS3692	□20	A6	—	—	—	—	
			TS3641	□28	A3	A6	A6	—	—	
			TS3617	□42	—	A5	A5	B1	—	
			TS3653	□56.4	—	—	—	A5	—	
			SM-L5MH	□28	A3	A6	A6	—	—	
		Si super	SM-02MH/ SM-04MH	□42	—	A5	A5	B1	—	
			SM-09MH/ SM-12MH	□56.4	—	—	—	A5	—	

* Please contact NB for the coupling because the motor shaft length will be shortened.

BG15

Figures inside () indicates mass of the motor mount adapter plate.

A0

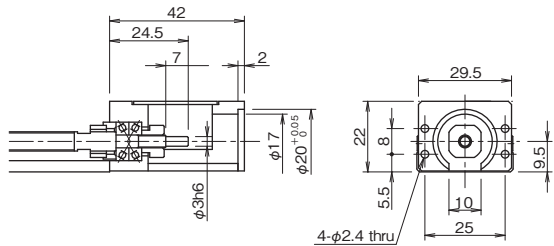

A1 (Mass: 9g)

Recommended Coupling:
XBW-15C2(Nabeya Bi-tech Kaisha)
SFC-005DA2(Miki Pully Co., Ltd.)

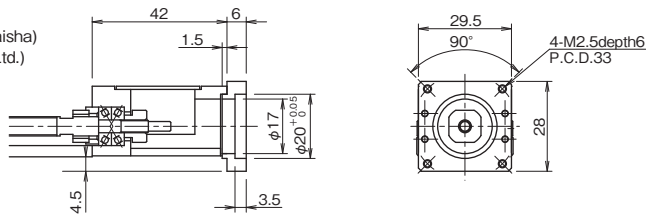

A2 (Mass: 8g)

Recommended Coupling:
XBW-15C2(Nabeya Bi-tech Kaisha)
LAD-15C(Sakai Manufacturing Co., Ltd.)
SFC-005DA2(Miki Pully Co., Ltd.)

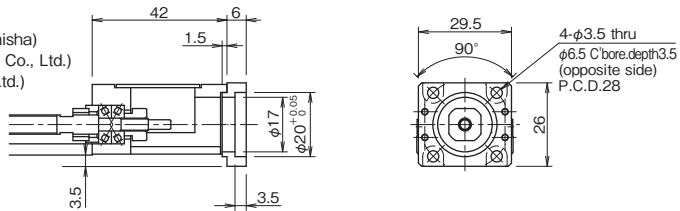

A3 (Mass: 9g)

Recommended Coupling:
XBW-15C2(Nabeya Bi-tech Kaisha)
LAD-15C(Sakai Manufacturing Co., Ltd.)
SFC-005DA2(Miki Pully Co., Ltd.)

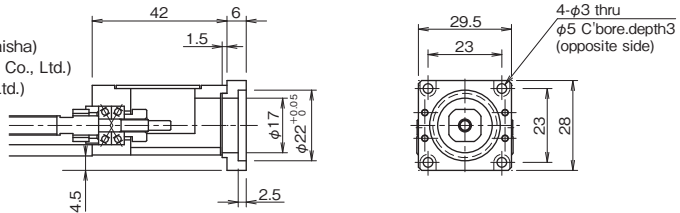

A4 (Mass: 8g)

Recommended Coupling:
XBW-15C2(Nabeya Bi-tech Kaisha)
LAD-15C(Sakai Manufacturing Co., Ltd.)
SFC-005DA2(Miki Pully Co., Ltd.)

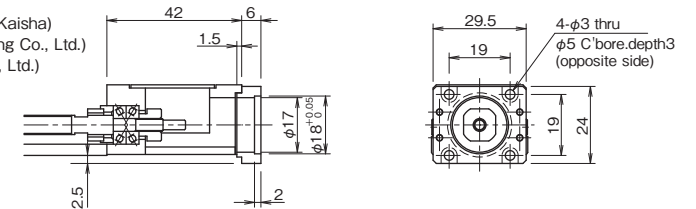

A5 (Mass: 4g)

Recommended Coupling:
XBW-15C2(Nabeya Bi-tech Kaisha)

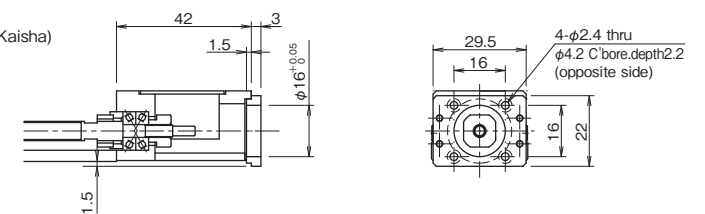

A6 (Mass: 4g)

Recommended Coupling:
XBW-15C2(Nabeya Bi-tech Kaisha)

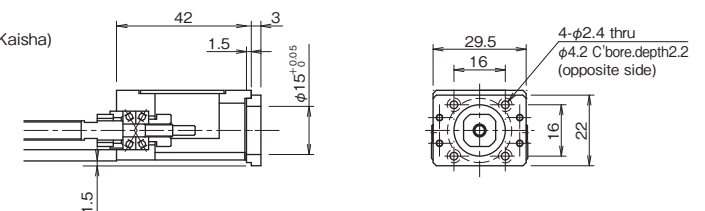

A7 (Mass: 11g)

Recommended Coupling:
XBW-15C2(Nabeya Bi-tech Kaisha)
LAD-15C(Sakai Manufacturing Co., Ltd.)

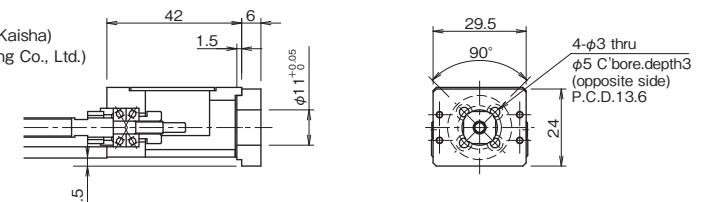

Attach the motor to the motor mount adapter plate first.

BG20

Figures inside () indicates mass of the motor mount adapter plate.

A0

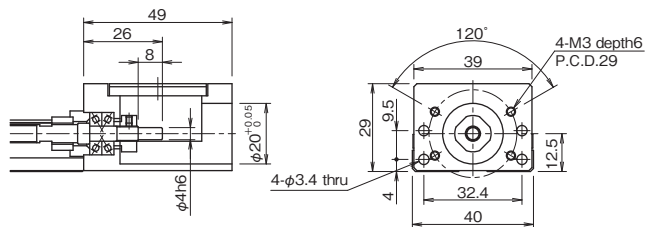

A1 (Mass: 38g)

Recommended Coupling:
XBW-19C2(Nabeya Bi-tech Kaisha)
SFC-010DA2(Miki Pulley Co., Ltd.)

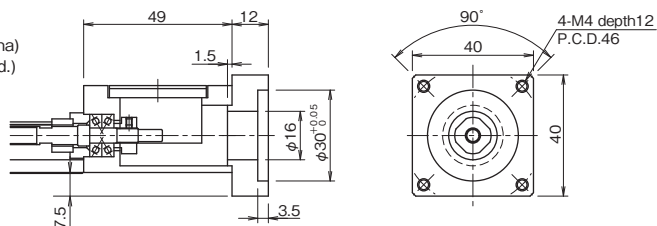

A3 (Mass: 39g)

Recommended Coupling:
XBW-19C2(Nabeya Bi-tech Kaisha)
SFC-010DA2(Miki Pulley Co., Ltd.)

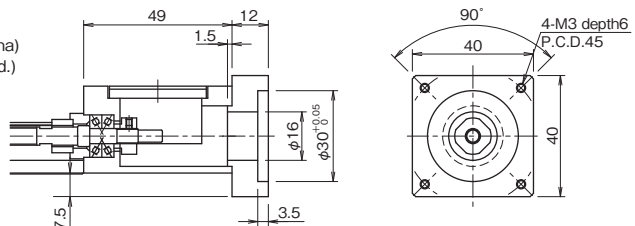

A5 (Mass: 26g)

Recommended Coupling:
XBW-19C2(Nabeya Bi-tech Kaisha)
SFC-010DA2(Miki Pulley Co., Ltd.)

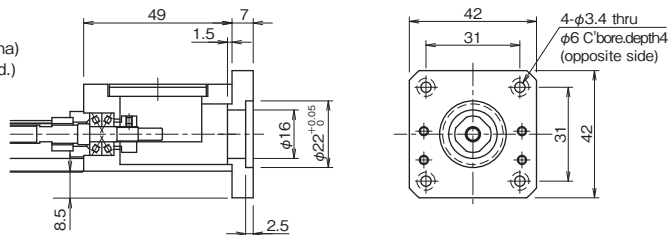

A6 (Mass: 10g)

Recommended Coupling:
XBW-19C2(Nabeya Bi-tech Kaisha)
SFC-010DA2(Miki Pulley Co., Ltd.)

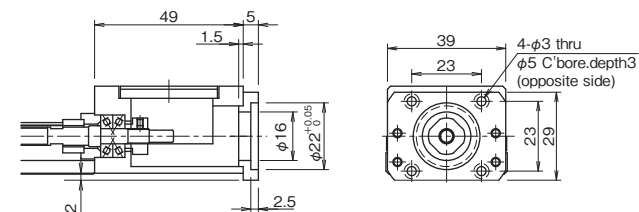

A8 (Mass: 12g)

Recommended Coupling:
XBW-19C2(Nabeya Bi-tech Kaisha)
SFC-010DA2(Miki Pulley Co., Ltd.)

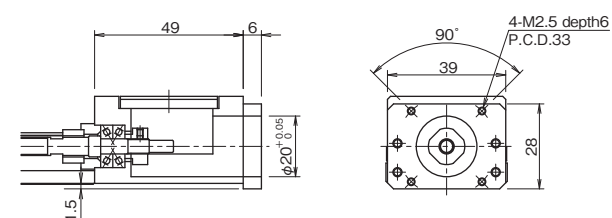

A9 (Mass: 14g)

Recommended Coupling:
XBW-19C2(Nabeya Bi-tech Kaisha)
SFC-010DA2(Miki Pulley Co., Ltd.)

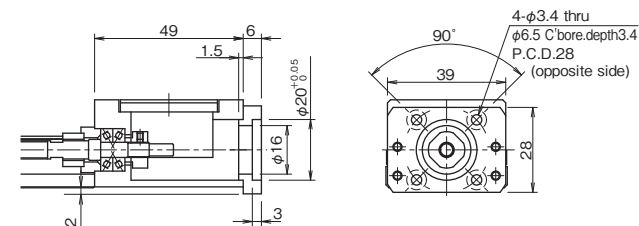

AA (Mass: 46g)

Recommended Coupling:
XBW-19C2(Nabeya Bi-tech Kaisha)
SFC-010DA2(Miki Pulley Co., Ltd.)

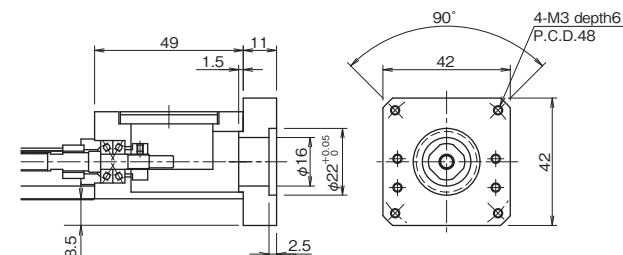

For configurations A5, A6, A9 and AA, attach the motor to the motor mount adapter plate first.

BG26

Figures inside () indicates mass of the motor mount adapter plate.

A0

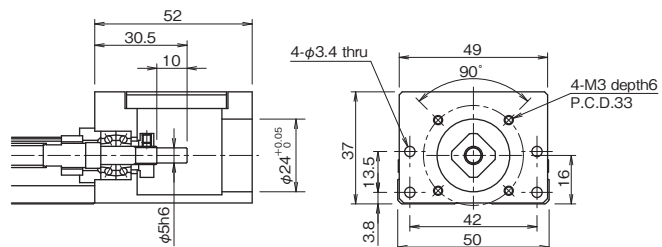

A1 (Mass:28g)

Recommended Coupling:
 XBW-19C2(Nabeya Bi-tech Kaisha)
 LAD-20C(Sakai Manufacturing Co., Ltd.)
 SFC-010DA2(Miki Pulley Co., Ltd.)

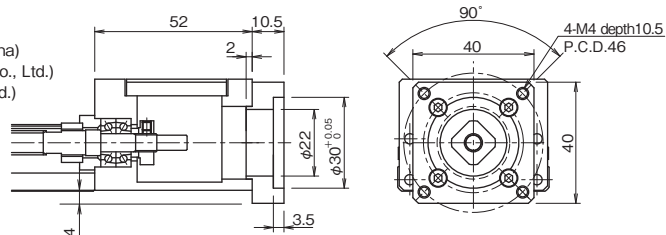

A3 (Mass:24g)

Recommended Coupling:
 XBW-19C2(Nabeya Bi-tech Kaisha)
 LAD-20C(Sakai Manufacturing Co., Ltd.)
 SFC-010DA2(Miki Pulley Co., Ltd.)

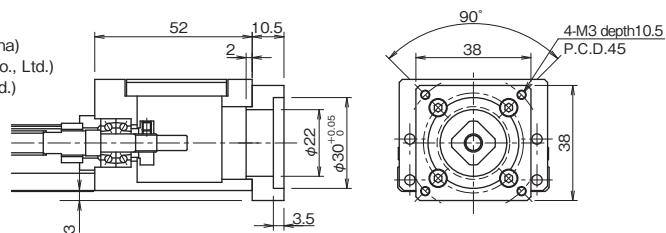

A5 (Mass:32g)

Recommended Coupling:
 XBW-19C2(Nabeya Bi-tech Kaisha)
 LAD-20C(Sakai Manufacturing Co., Ltd.)
 SFC-010DA2(Miki Pulley Co., Ltd.)

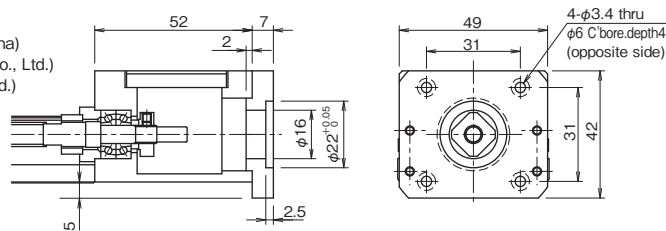

A6 (Mass:16g)

Recommended Coupling:
 XBW-19C2(Nabeya Bi-tech Kaisha)
 LAD-20C(Sakai Manufacturing Co., Ltd.)
 SFC-010DA2(Miki Pulley Co., Ltd.)

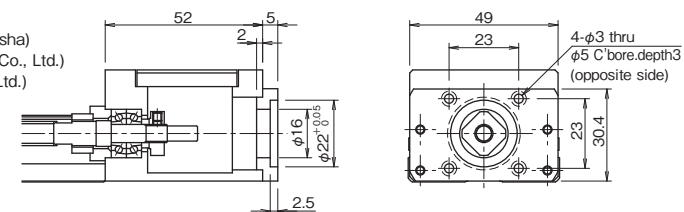

A8 (Mass:21g)

Recommended Coupling:
 XBW-19C2(Nabeya Bi-tech Kaisha)
 LAD-20C(Sakai Manufacturing Co., Ltd.)
 SFC-010DA2(Miki Pulley Co., Ltd.)

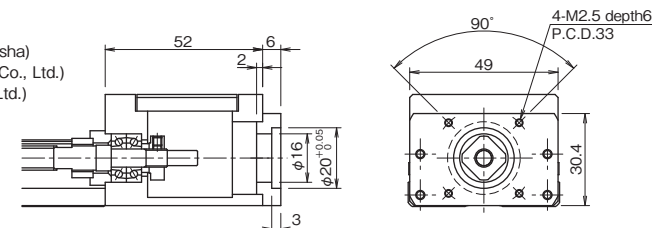

A9 (Mass:21g)

Recommended Coupling:
 XBW-19C2(Nabeya Bi-tech Kaisha)
 LAD-20C(Sakai Manufacturing Co., Ltd.)
 SFC-010DA2(Miki Pulley Co., Ltd.)

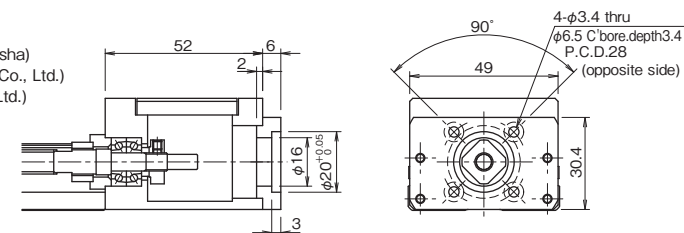

AA (Mass:41g)

Recommended Coupling:
 XBW-19C2(Nabeya Bi-tech Kaisha)
 LAD-20C(Sakai Manufacturing Co., Ltd.)
 SFC-010DA2(Miki Pulley Co., Ltd.)

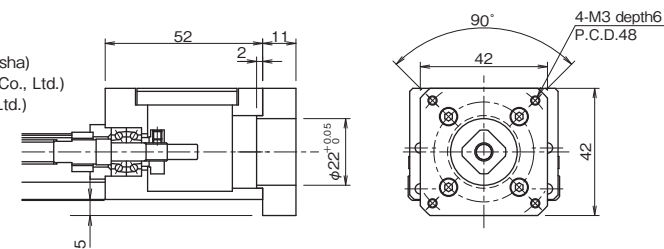

For configurations A5, A6 and A9, attach the motor to the motor mount adapter plate first.

BG33

Figures inside () indicates mass of the motor mount adapter plate.

A0

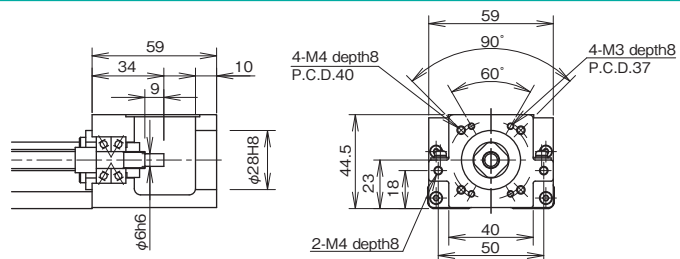

A1 (Mass:66g)

Recommended Coupling:
 XBW-25C2(Nabeya Bi-tech Kaisha)
 LAD-25C(Sakai Manufacturing Co., Ltd.)
 SFC-020DA2(Miki Pulley Co., Ltd.)

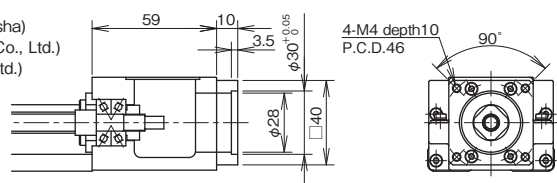

A2 (Mass:67g)

Recommended Coupling:
 XBW-25C2(Nabeya Bi-tech Kaisha)
 LAD-25C(Sakai Manufacturing Co., Ltd.)
 SFC-020DA2(Miki Pulley Co., Ltd.)

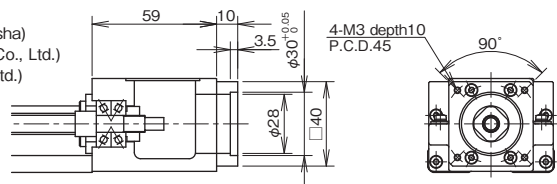

A3 (Mass:133g)

Recommended Coupling:
 XBW-25C2(Nabeya Bi-tech Kaisha)
 LAD-25C(Sakai Manufacturing Co., Ltd.)
 SFC-020DA2(Miki Pulley Co., Ltd.)

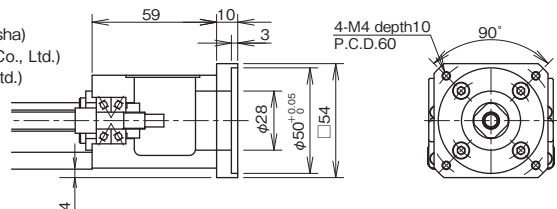

A5 (Mass:125g)

Recommended Coupling:
 XBW-25C2(Nabeya Bi-tech Kaisha)
 LAD-25C(Sakai Manufacturing Co., Ltd.)
 SFC-020DA2(Miki Pulley Co., Ltd.)

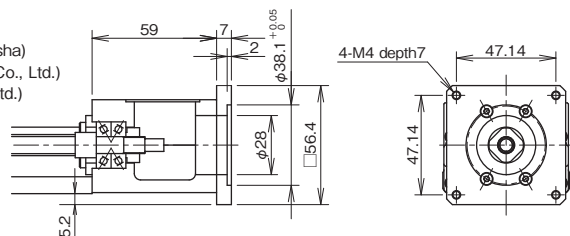

A6 (Mass:215g)

Recommended Coupling:
 XBW-27C2(Nabeya Bi-tech Kaisha)

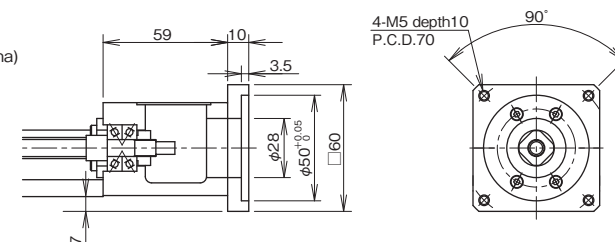

A7 (Mass:215g)

Recommended Coupling:
 XBW-27C2(Nabeya Bi-tech Kaisha)

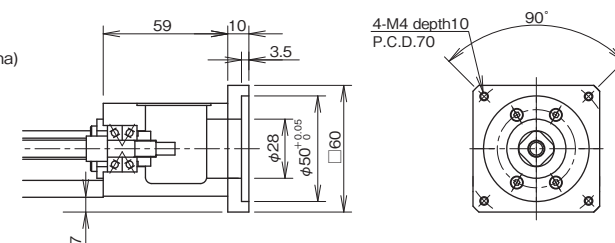

A8 (Mass:212g)

Recommended Coupling:
 XBW-25C2(Nabeya Bi-tech Kaisha)*
 LAD-25C(Sakai Manufacturing Co., Ltd.)*
 SFC-020DA2(Miki Pulley Co., Ltd.)*
 *Please contact NB if you are using α STEP motor (Oriental Motor Co., Ltd.)

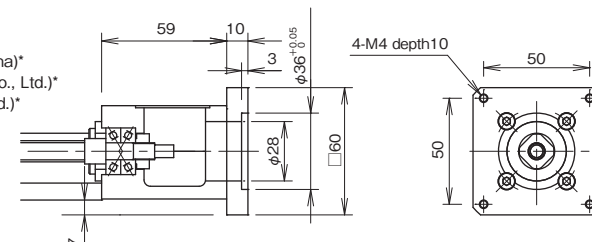

B1 (Mass:111g)

Recommended Coupling:
 XBW-19C2(Nabeya Bi-tech Kaisha)
 LAD-20C(Sakai Manufacturing Co., Ltd.)
 SFC-010DA2(Miki Pulley Co., Ltd.)

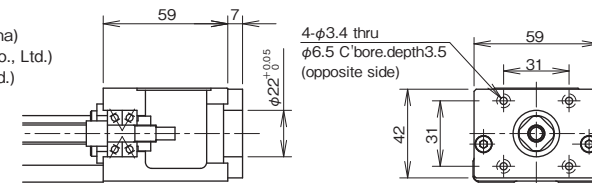

B2 (Mass:167g)

Recommended Coupling:
 XBW-19C2(Nabeya Bi-tech Kaisha)
 LAD-25C(Sakai Manufacturing Co., Ltd.)

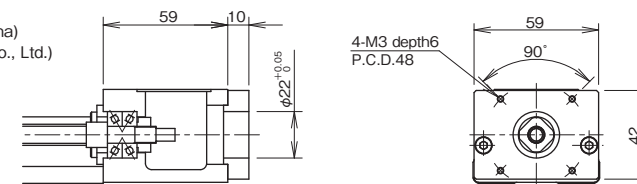

For configurations B1 and B2, attach the motor to the motor mount adapter plate first.

BG46

Figures inside () indicates mass of the motor mount adapter plate.

AO

Recommended Coupling:
 XBW-25C2(Nabeya Bi-tech Kaisha)
 LAD-25C(Sakai Manufacturing Co., Ltd.)
 SFC-020DA2(Miki Pulley Co., Ltd.)

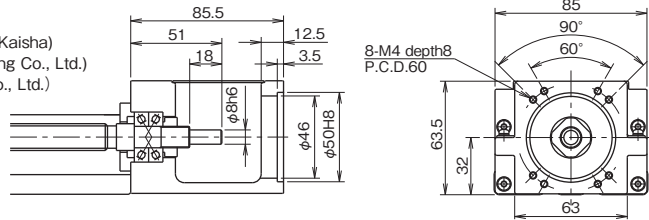

A1 (Mass:103g)

Recommended Coupling:
 XBW-34C3(Nabeya Bi-tech Kaisha)
 LAD-30C(Sakai Manufacturing Co., Ltd.)
 SFC-030DA2(Miki Pulley Co., Ltd.)

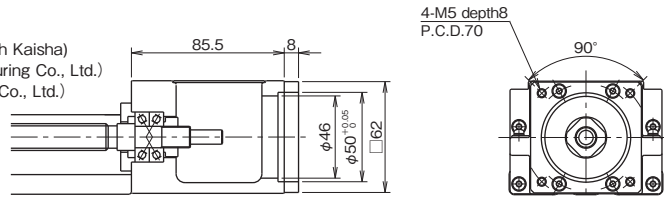

A2 (Mass:106g)

Recommended Coupling:
 XBW-34C3(Nabeya Bi-tech Kaisha)
 LAD-30C(Sakai Manufacturing Co., Ltd.)
 SFC-030DA2(Miki Pulley Co., Ltd.)

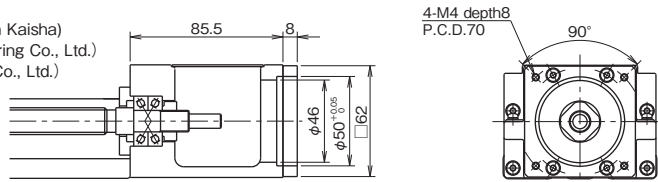

A3 (Mass:448g)

Recommended Coupling
 (200W-400W):
 XBW-34C3(Nabeya Bi-tech Kaisha)
 SFC-030DA2(Miki Pulley Co., Ltd.)
 (750W):
 XBW-39C2
 (Nabeya Bi-tech Kaisha)
 SFC-040DA2
 (Miki Pulley Co., Ltd.)

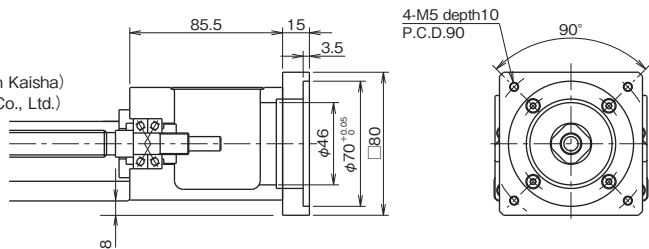

A4 (Mass:628g)

Recommended Coupling:
 XBW-39C2(Nabeya Bi-tech Kaisha)
 SFC-040DA2(Miki Pulley Co., Ltd.)

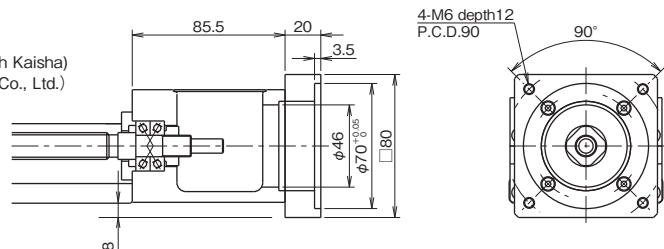

BO

Recommended Coupling:
 XBW-25C2(Nabeya Bi-tech Kaisha)
 LAD-25C(Sakai Manufacturing Co., Ltd.)
 SFC-020DA2(Miki Pulley Co., Ltd.)

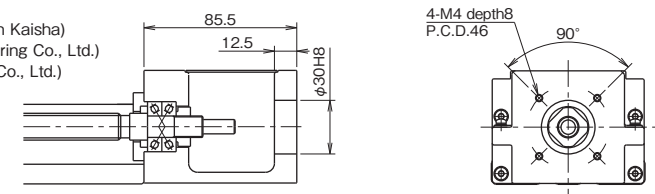

CO

Recommended Coupling:
 XBW-25C2(Nabeya Bi-tech Kaisha)
 LAD-25C(Sakai Manufacturing Co., Ltd.)
 SFC-020DA2(Miki Pulley Co., Ltd.)

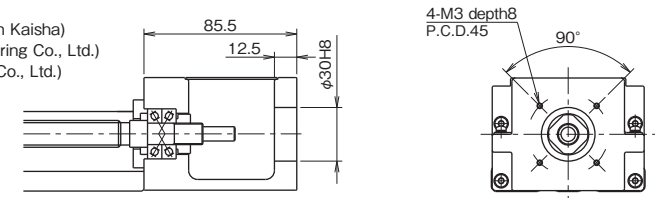

DO

Recommended Coupling:
 XBW-27C2(Nabeya Bi-tech Kaisha)
 LAD-25C(Sakai Manufacturing Co., Ltd.)*
 SFC-020DA2(Miki Pulley Co., Ltd.)*
 *Please contact NB if you are using αSTEP motor (Oriental Motor Co., Ltd.)

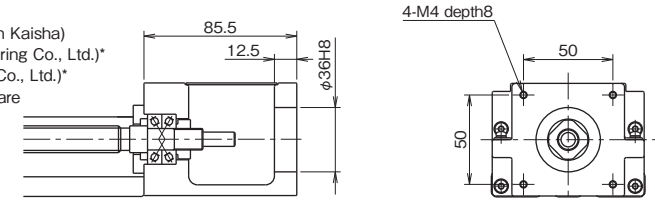

D1 (Mass:435g)

Recommended Coupling:
 XBW-34C3(Nabeya Bi-tech Kaisha)*
 LAD-35C(Sakai Manufacturing Co., Ltd.)*
 *Please contact NB if you are using αSTEP motor (Oriental Motor Co., Ltd.)

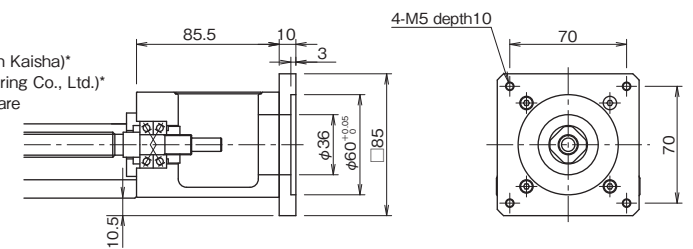

BG55

Figures inside() indicates mass of the motor mount adapter plate.

A0

Recommended Coupling:
 XBW-34C3(Nabeya Bi-tech Kaisha)
 LAD-35C(Sakai Manufacturing Co., Ltd.)
 SFC-035DA2(Miki Pulley Co., Ltd.)

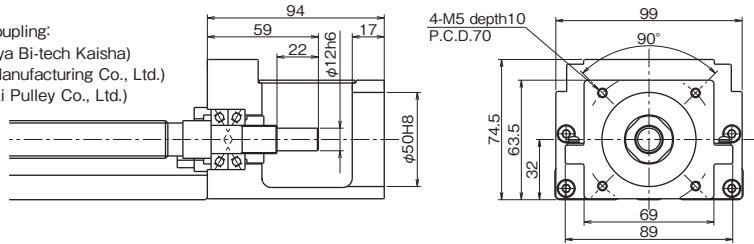

A1 (Mass:329g)

Recommended Coupling:
 XBW-39C2(Nabeya Bi-tech Kaisha)
 LAD-40C(Sakai Manufacturing Co., Ltd.)
 SFC-040DA2(Miki Pulley Co., Ltd.)

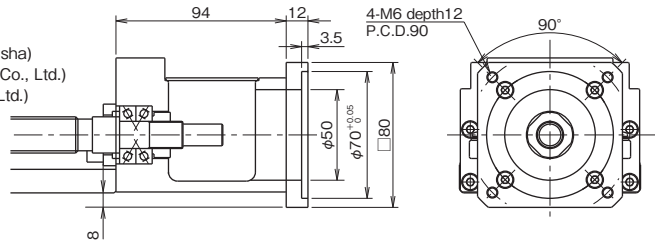

A2 (Mass:333g)

Recommended Coupling:
 XBW-39C2(Nabeya Bi-tech Kaisha)
 LAD-40C(Sakai Manufacturing Co., Ltd.)
 SFC-040DA2(Miki Pulley Co., Ltd.)

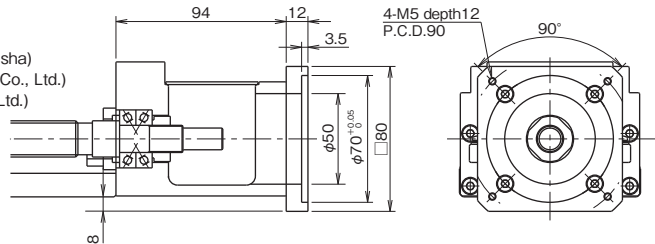

A3 (Mass:399g)

Recommended Coupling:
 XBW-39C2(Nabeya Bi-tech Kaisha)
 LAD-40C(Sakai Manufacturing Co., Ltd.)
 SFC-040DA2(Miki Pulley Co., Ltd.)

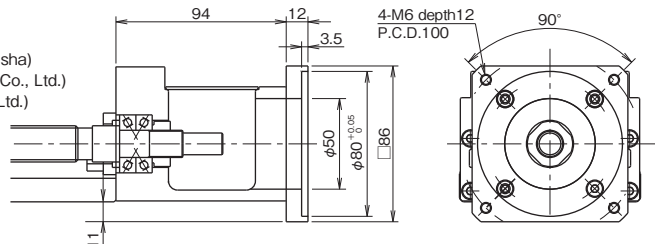

A4 (Mass:449g)

Recommended Coupling:
 XBW-39C2(Nabeya Bi-tech Kaisha)*
 LAD-40C(Sakai Manufacturing Co., Ltd.)*
 SFC-035DA2(Miki Pulley Co., Ltd.)*
 *Please contact NB if you are using aSTEP motor (Oriental Motor Co., Ltd.).

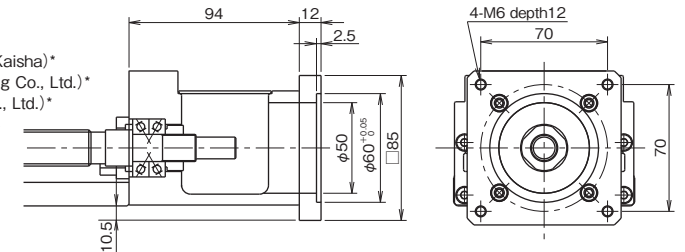

A5 (Mass:449g)

Recommended Coupling:
 XBW-39C2(Nabeya Bi-tech Kaisha)
 LAD-40C(Sakai Manufacturing Co., Ltd.)*
 SFC-035DA2(Miki Pulley Co., Ltd.)
 *Please note that the motor's maximum torque should be set within the coupling's allowable torque.

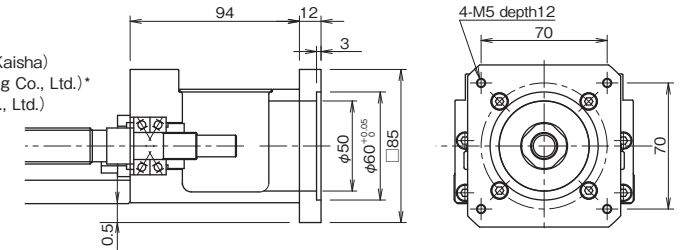

EXPOSED BRACKET R0

The ball screw shaft end is exposed with the exposed bracket R0 type. Please fabricate an original bracket in case the standard brackets are not applicable. R0 type is applicable with cover and with sensors.

BG15

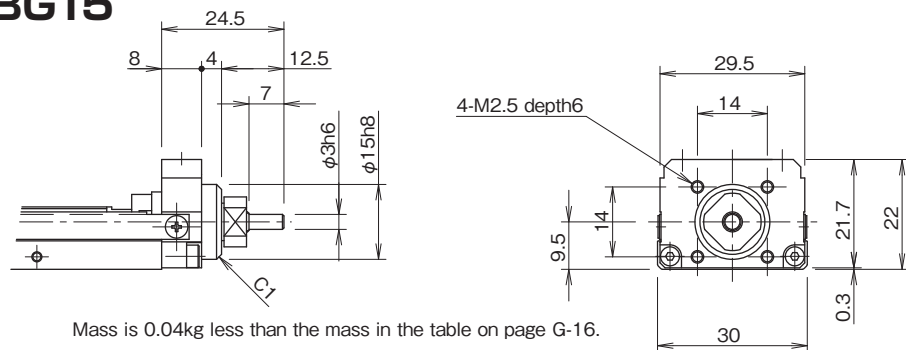

Mass is 0.04kg less than the mass in the table on page G-16.

BG33

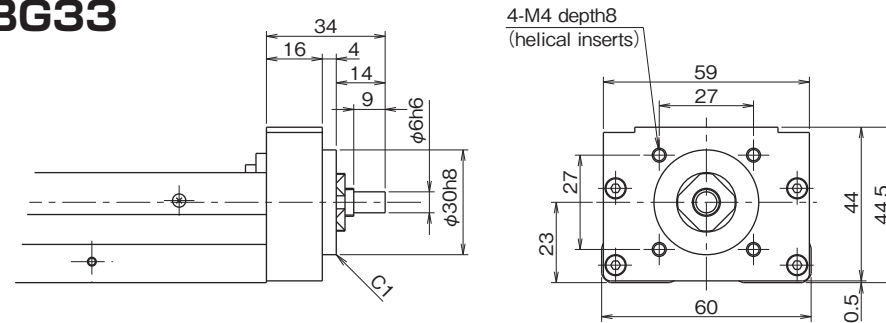

Mass is 0.1kg less than the mass in the table on page G-22, 24.

BG20

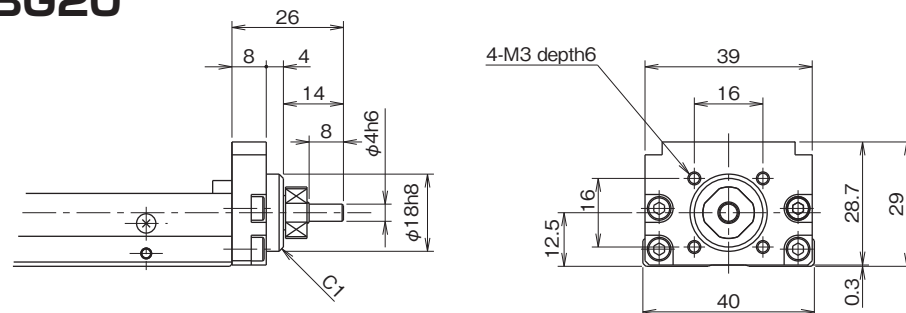

Mass is 0.04kg less than the mass in the table on page G-18.

BG46

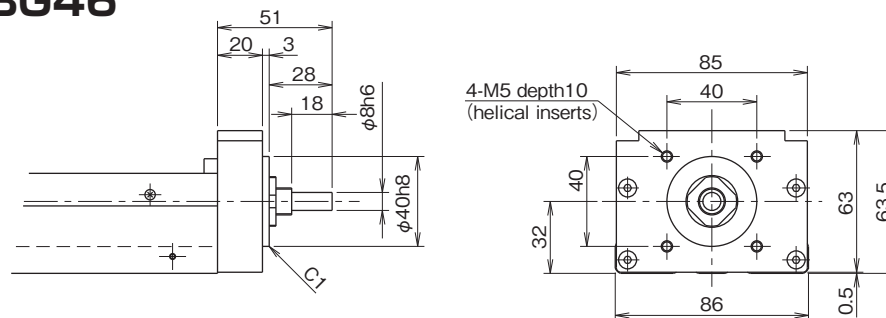

Mass is 0.3kg less than the mass in the table on page G-26, 28.

BG26

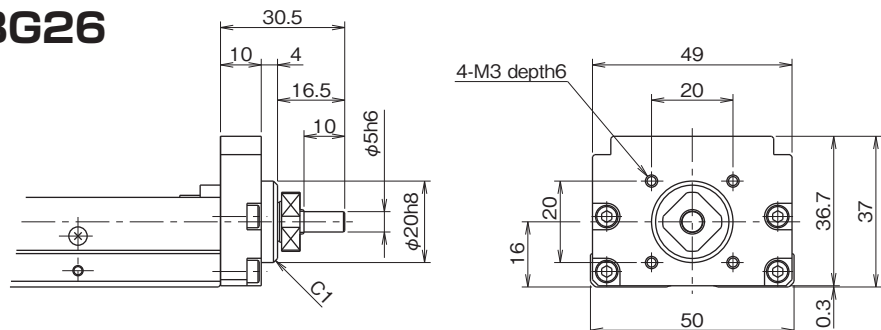

Mass is 0.08kg less than the mass in the table on page G-20.

BG55

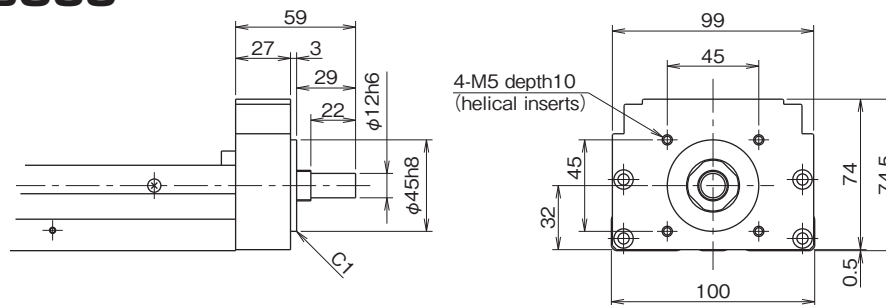

Mass is 0.3kg less than the mass in the table on page G-30.

RETURN PULLEY UNIT

Return pulley units in which a motor is connected with a timing belt are available for BG type. Its return structure allows the reduction of total length (available for BG33 and BG46).

BG33

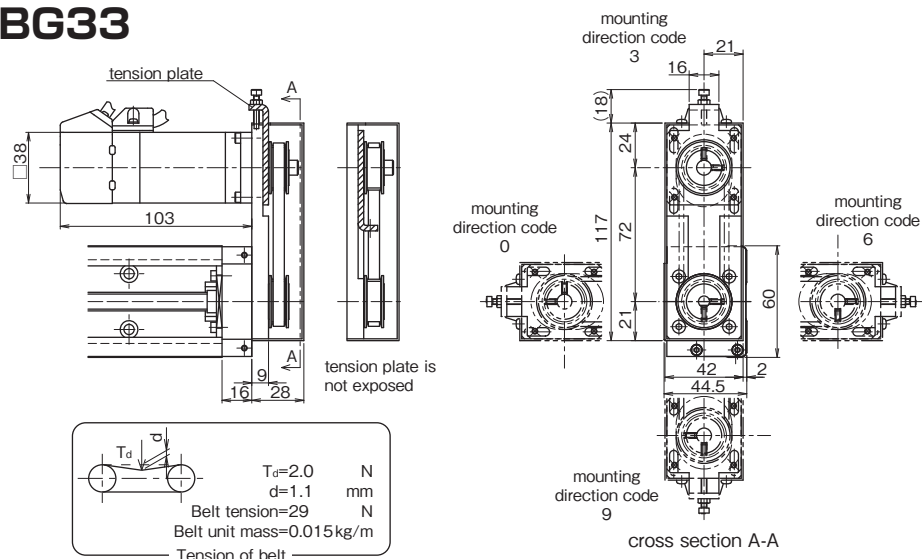

- 1.This drawing shows RA for MSMA01(Panasonic).
- 2.Installation position of Pulley Unit can be selected at 90° intervals (mounting direction code).
- 3.Applicable with cover and with sensors.
Precaution for applying H type sensors
When the motor is positioned at direction 3 or 9, H type sensors interfere if mounted on the side of motor.
H type sensors must be mounted opposite to the motor.
- 4.Tension plate can be built in and is not exposed. (not applicable to RC)
- 5.0.2kg is added to the mass on page G-22 ~ 25.
- 6.Inertia is added $2.22 \times 10^{-6} \text{kg} \cdot \text{m}^2$ to the value of Table on page G-22 ~ 25. (motor inertia not included)
- 7.Part number structure BG33***-****/☆☆□
☆☆: Symbol of applicable motor bracket (refer to Table G-15)
□: Mounting direction code (refer to cross section A-A)

Table G-15 Applicable Motor

motor bracket	applicable motors		output	flange	motor shaft diameter
RA	Panasonic	MINAS SERIES	50~100W	□38	φ8
RB	YASKAWA ELECTRIC	SIGMA SERIES	50~100W	□40	φ8
	MITSUBISHI ELECTRIC	MELSERVO SERIES	50~100W	□40	
	SANYO DENKI	SANMOTION Q1 SERIES	50~100W	□40	
RC	5 PHASE STEPPING MOTOR		-	□42	φ5

BG46

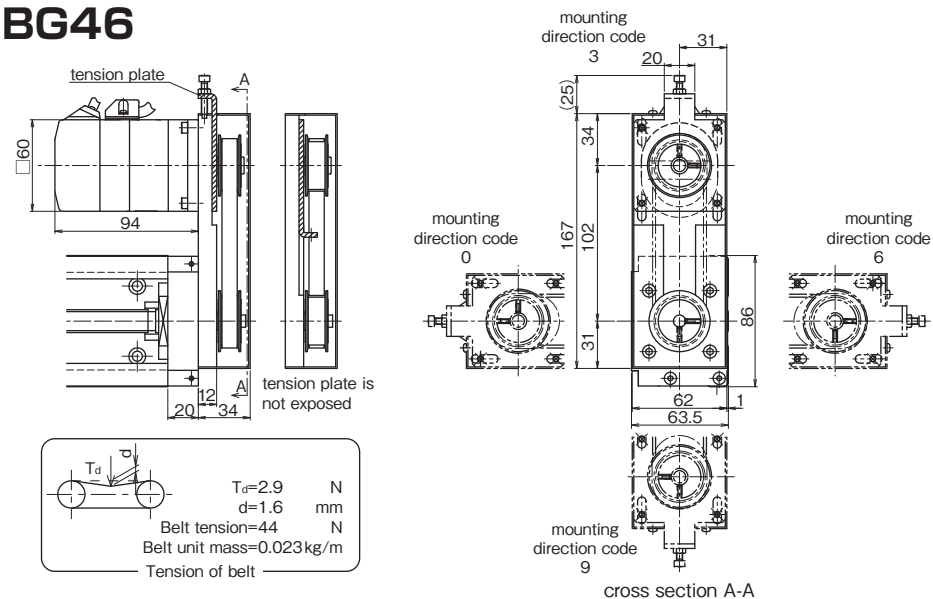

- 1.This drawing shows RA for MSMA02(Panasonic).
- 2.Installation position of Pulley Unit can be selected at 90° intervals (mounting direction code).
- 3.Applicable with cover and with sensors.
Precaution for applying H type sensors
When the motor is positioned at direction 3 or 9, H type sensors interfere if mounted on the side of motor.
H type sensors must be mounted opposite to the motor.
- 4.Tension plate can be built in and is not exposed.
- 5.0.7kg is added to the mass on page G-26 ~ 29.
- 6.Inertia is added $1.24 \times 10^{-5} \text{kg} \cdot \text{m}^2$ to the value of Table on page G-26 ~ 29. (motor inertia not included)
- 7.Parts number structure BG46***-****/☆☆□
☆☆: Symbol of applicable motor bracket (refer to Table G-16)
□: Mounting direction code (refer to cross section A-A)

Table G-16 Applicable Motor

motor bracket	applicable motors		output	flange	motor shaft diameter
RA	Panasonic	MINAS SERIES	200W	□60	φ11
RB	YASKAWA ELECTRIC	SIGMA SERIES	200W	□60	φ14
	MITSUBISHI ELECTRIC	MELSERVO SERIES	200W	□60	
	SANYO DENKI	SANMOTION Q1 SERIES	200W	□60	
RC	5 PHASE STEPPING MOTOR		-	□60	φ8

Return pulley units is available for sizes other than BG33 and BG46. Please contact NB.

LOW HOUSING

NB provides low housing with actuators. The height of housing is lower than the block. When the length of workpiece exceeds the guide block, it will interfere with standard housing. It is recommended to take low housing when long work is mounted.

Please note that the height of motor bracket cannot be lower any more.

BG15

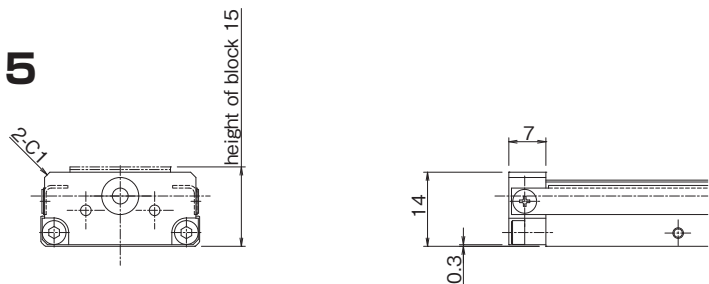

•Mass is 0.005kg less than the mass on page G-16.

BG20

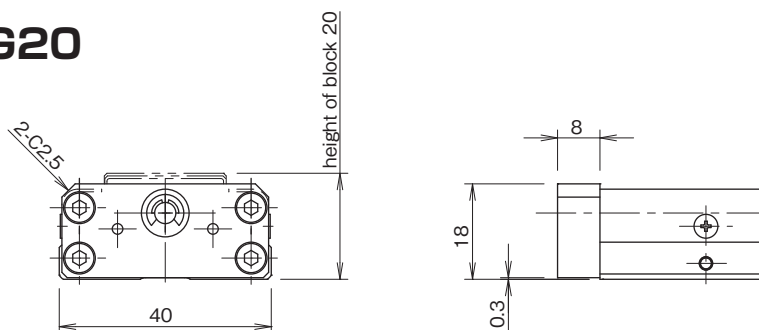

•Mass is 0.01kg less than the mass on page G-18.

BG26

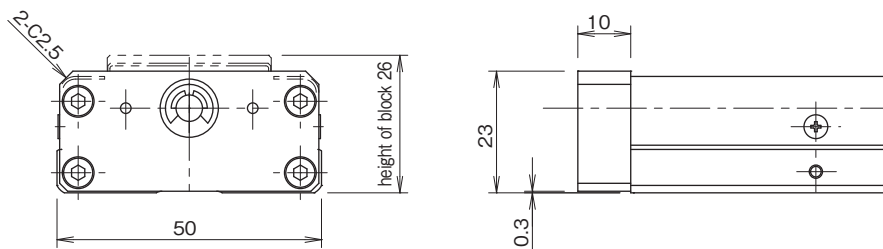

•Mass is 0.02kg less than the mass on page G-20.

BG33

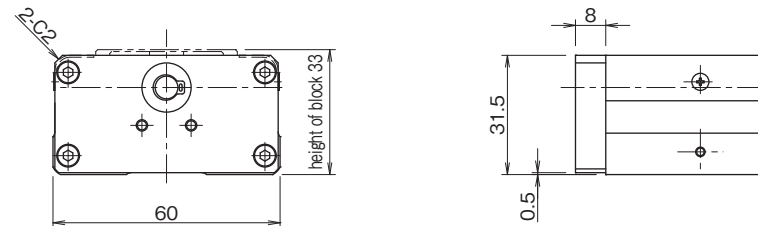

•Mass is 0.02kg less than the mass on page G-22, 24.

BG46

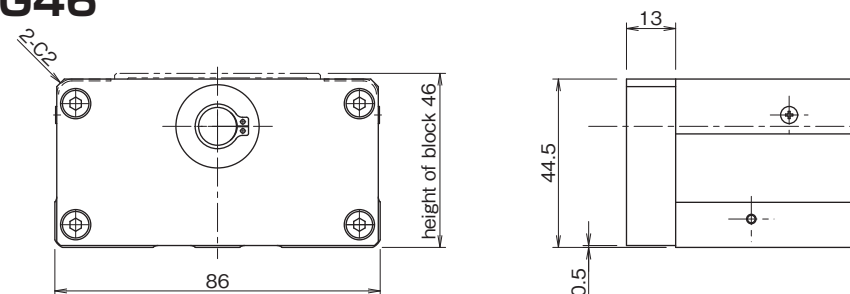

•Mass is 0.05kg less than the mass on page G-26, 28.

BG55

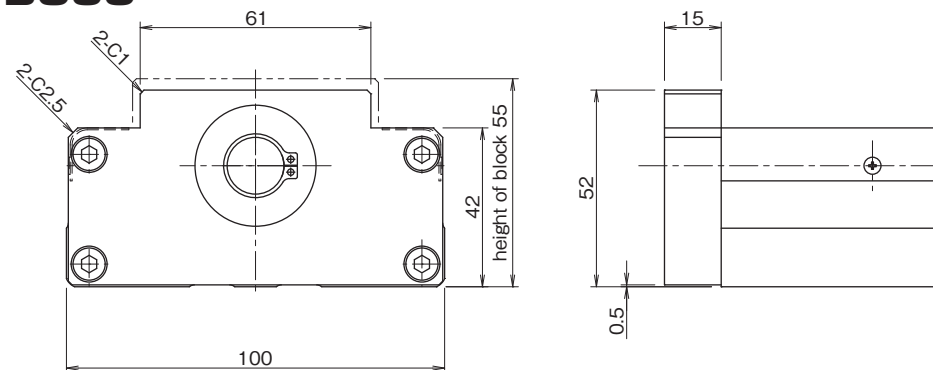

•Mass is 0.1kg less than the mass on page G-30.

BELLOWS

BG type can be specified with a cover or bellows for dust prevention. Bellows are securely fixed for various installation methods in positioning and directions. Sensor for bellows is limited to K (proximity sensor) type only, which is pre-installed at proper positions.

Please pay attention to the stroke limit of BG with bellows that is shorter than the standard stroke limit.

– Position of Sensor Cable Outlet –

The positions of the outlet for sensor cables can be selected as Figure G-14 shows.

Figure G-14 Position of Sensor Cable Outlet

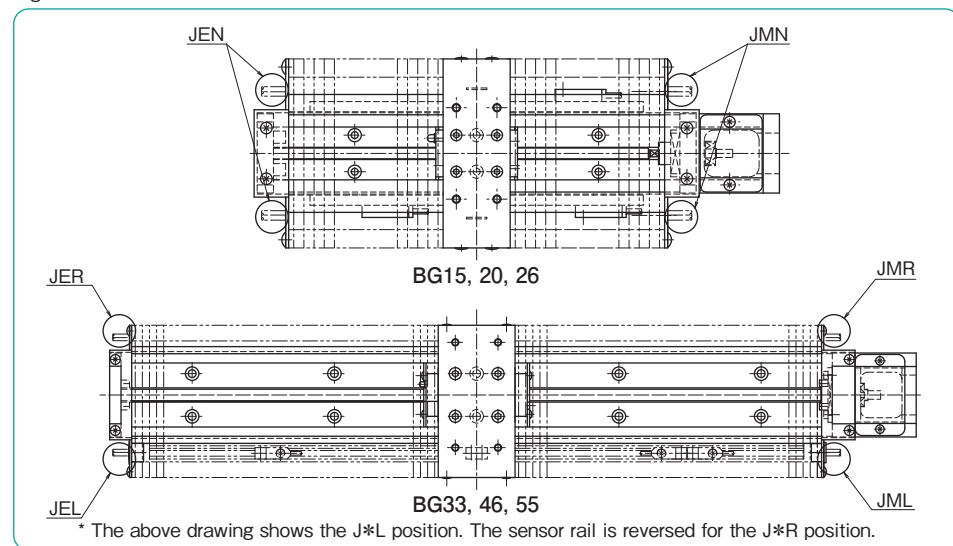

part number structure for bellows

1. J (for the first symbol)
2. Specification of the position of the sensor cable outlet
Please select the motor side or the housing side.
M: motor side E: housing side (end plate side)
3. Specification of the position of the sensor rail
Please select the right hand or the left hand.
R: on the right from the motor side
L: on the left from the motor side
*N for BG15, 20, and 26 since the sensors are mounted on both the right and left hand.
4. JNN for without sensors
5. Sensor type is K (proximity sensor) type only (APM-D3 series: Azbil).

– Sensor Timing Chart –

The following chart shows the standard sensor arrangement.

Figure G-15 Sensor Timing Chart

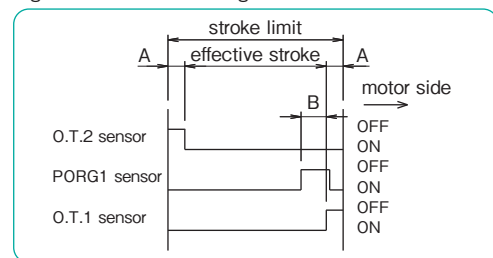

BG15
A(1 long block)

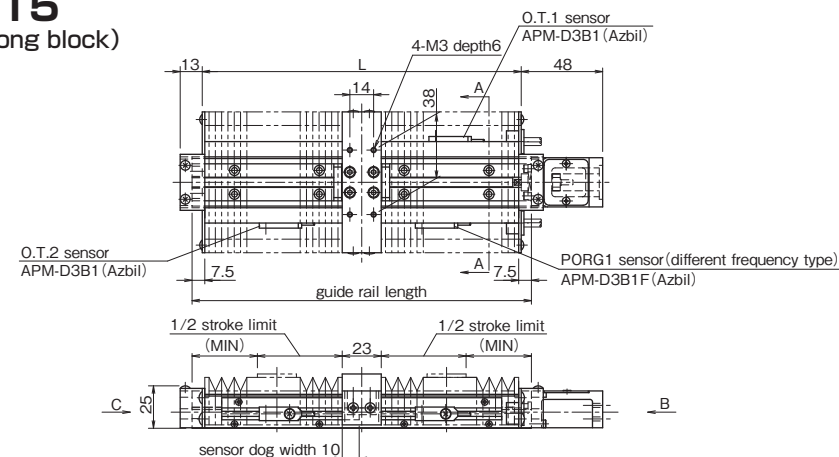

B(2 long blocks in close contact)

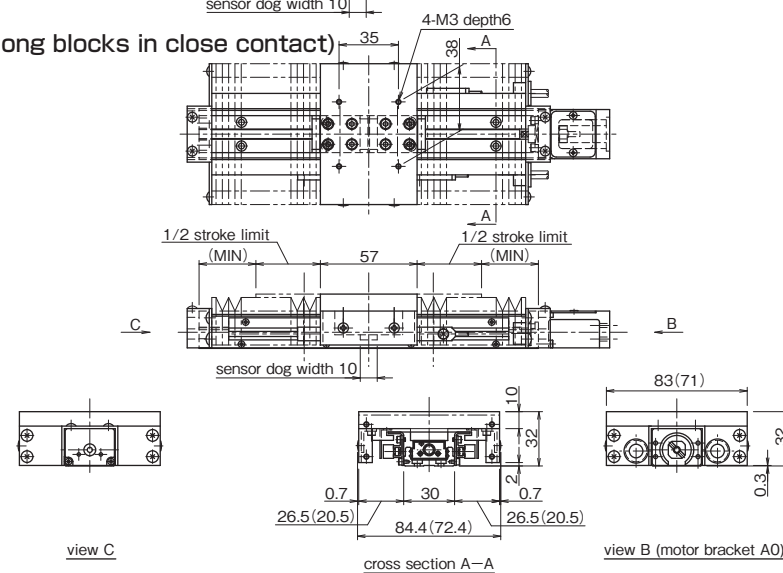

1. The drawings show the "JMN" configuration.
2. The numbers in the parentheses are the dimensions when sensors are not selected.
3. Please refer to page G-16 for dimensions that are not shown on the drawings.
4. material of bellows: composite resin sheet (glossy black)

rail length	L	1 long block			2 long blocks		
		stroke limit	effective stroke	MIN	stroke limit	effective stroke	MIN
75	—	—	—	—	—	—	—
100	—	—	—	—	—	—	—
125	113	43	33	29.5	—	—	—
150*	138	60	50	33.5	40	30	26.5
175	163	85	75	33.5	59	49	29.5
200	188	100	90	38.5	76	60	33.5

* The rail mounting holes at the center cannot be used for the rail length 150 with two long blocks.

BG20

A(1 long block)

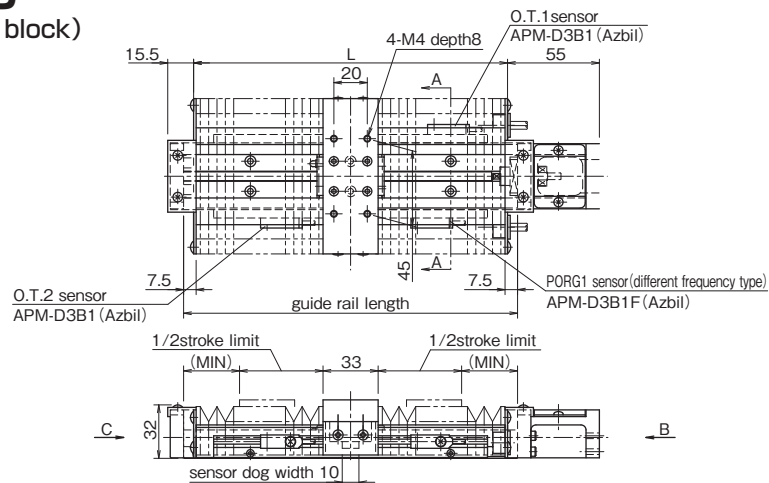

B(2 long blocks in close contact)

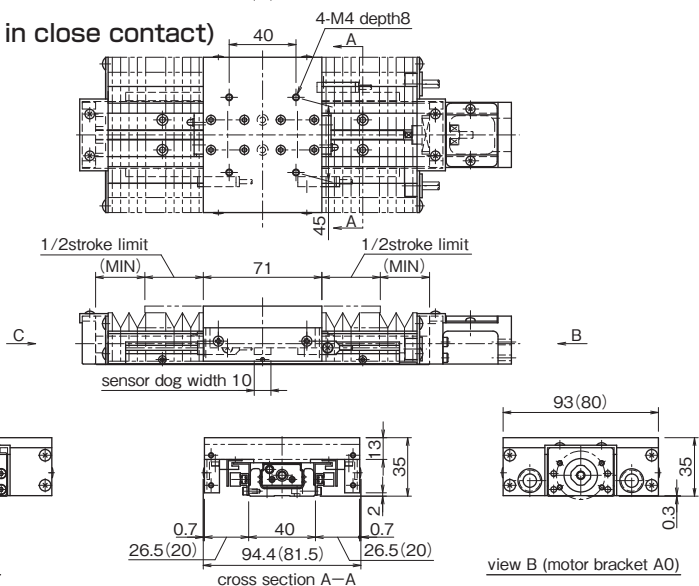

- 1.The drawings show the "JMN" configuration.
- 2.The numbers in the parentheses are the dimensions when sensors are not selected.
- 3.Please refer to page G-18 for dimensions that are not shown on the drawings.
- 4.material of bellows: composite resin sheet (glossy black)

rail length	L	1 long block		2 long blocks			
		stroke limit	effective stroke	MIN	stroke limit	effective stroke	MIN
100	—	—	—	—	—	—	
150	138	58	48	29.5	32	22	23.5
200	188	100	90	33.5	70	60	29.5

* The rail mounting holes at the center cannot be used for the rail length 150 with two long blocks.

BG26

A(1 long block)

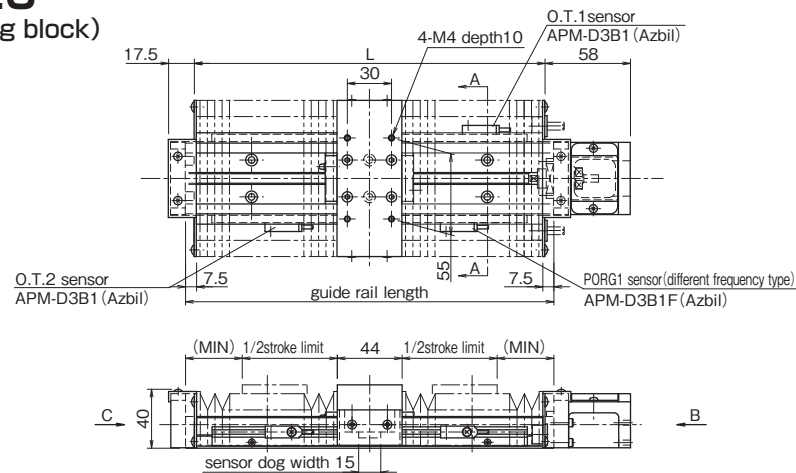

B(2 long blocks in close contact)

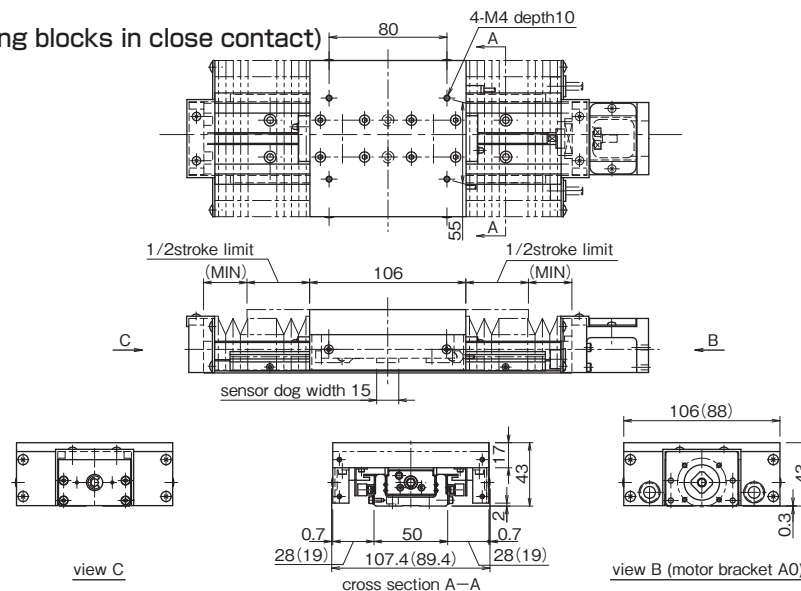

- 1.The drawings show the "JMN" configuration.
- 2.The numbers in the parentheses are the dimensions when sensors are not selected.
- 3.Please refer to page G-20 for dimensions that are not shown on the drawings.
- 4.material of bellows: composite resin sheet (glossy black)

rail length	L	1 long block		2 long blocks			
		stroke limit	effective stroke	MIN	stroke limit	effective stroke	MIN
150	138	53	43	26.5	—	—	
200	188	97	87	29.5	41	31	26.5
250	238	129	119	38.5	85	75	29.5
300	288	169	159	43.5	127	117	33.5

* The rail mounting holes at the center cannot be used for the rail length 200 with two long blocks.

BG33

A(1 long block)

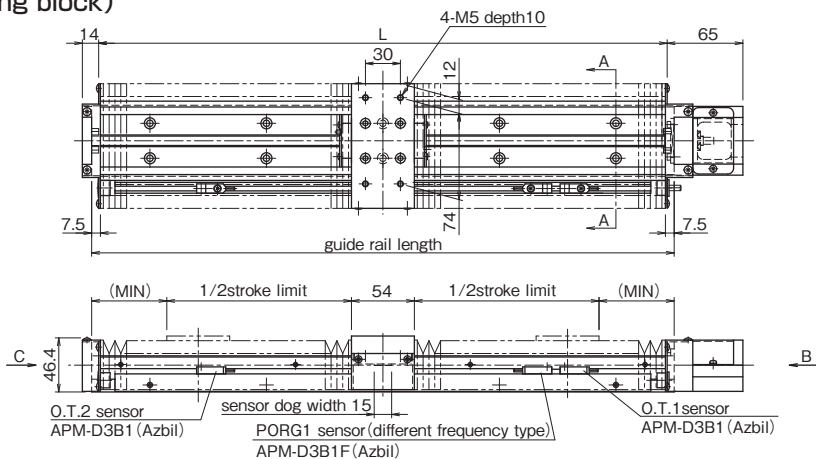

B(2 long blocks in close contact)

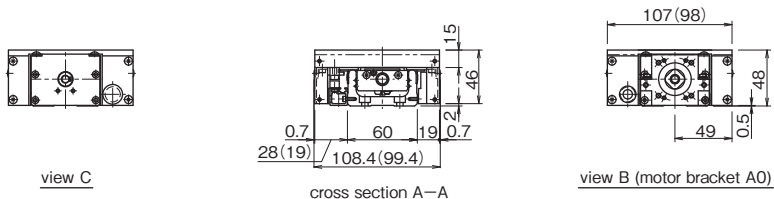
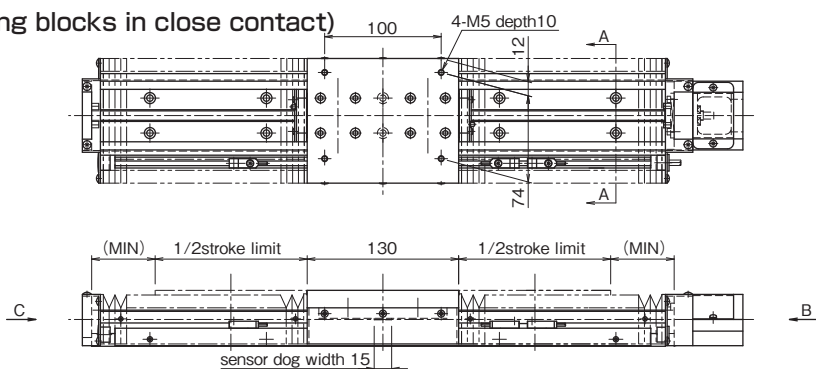

- The drawings show the "JML" configuration. The cross sections become reversed when "J *R" is selected.
- The numbers in the parentheses are the dimensions when sensors are not selected.
- Please refer to page G-22 for dimensions that are not shown on the drawings.
- material of bellows: composite resin sheet (glossy black)

rail length	L	1 long block			2 long blocks		
		stroke limit	effective stroke	MIN	stroke limit	effective stroke	MIN
150	—	—	—	—	—	—	—
200	188	79	59	33.5	—	—	—
300*	288	159	139	43.5	103	83	33.5
400	388	237	217	54.5	183	163	43.5
500	488	317	297	64.5	261	241	54.5
600	588	395	375	75.5	341	321	64.5

*The rail mounting holes at the center cannot be used for the rail length 300 with two long blocks.

BG33

C(1 short block)

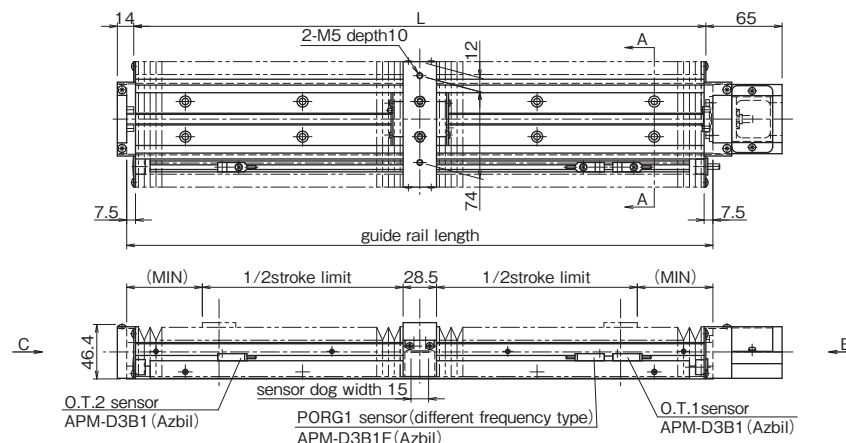

D(2 short blocks in close contact)

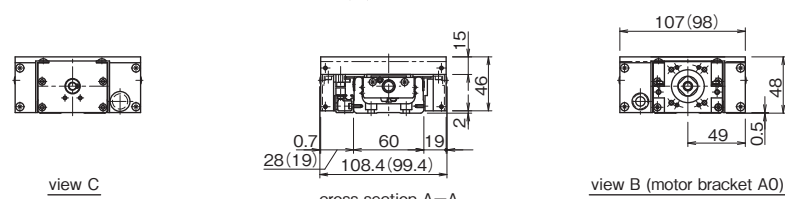
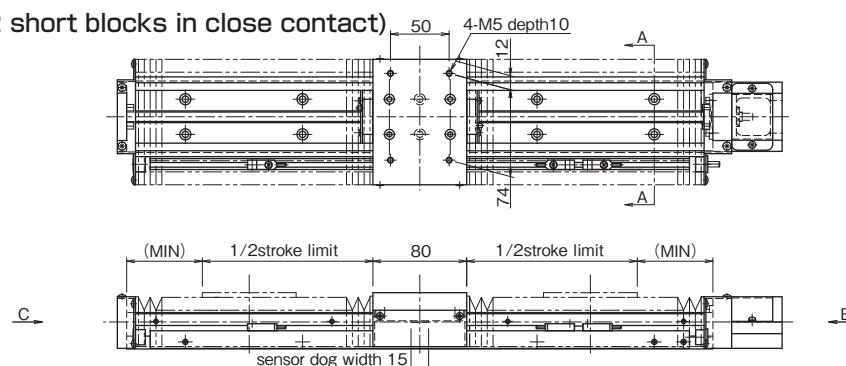

- The drawings show the "JML" configuration. The cross sections become reversed when "J *R" is selected.
- The numbers in the parentheses are the dimensions when sensors are not selected.
- Please refer to page G-24 for dimensions that are not shown on the drawings.
- material of bellows: composite resin sheet (glossy black)

rail length	L	1 short block			2 short blocks		
		stroke limit	effective stroke	MIN	stroke limit	effective stroke	MIN
150	138	68.5	48.5	26.5	—	—	—
200	188	104.5	84.5	33.5	67	47	26.5
300	288	184.5	164.5	43.5	143	123	38.5
400	388	262.5	242.5	54.5	211	191	54.5
500	488	342.5	322.5	64.5	291	271	64.5
600	588	404.5	384.5	83.5	369	349	75.5

BG46

A(1 long block)

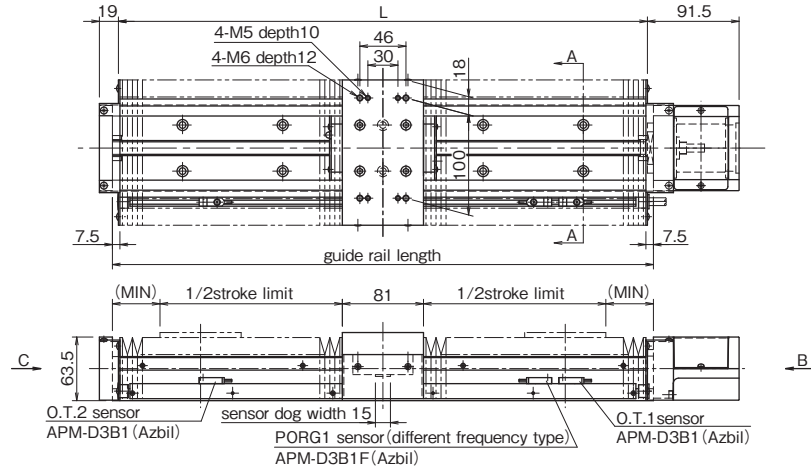

B(2 long blocks in close contact)

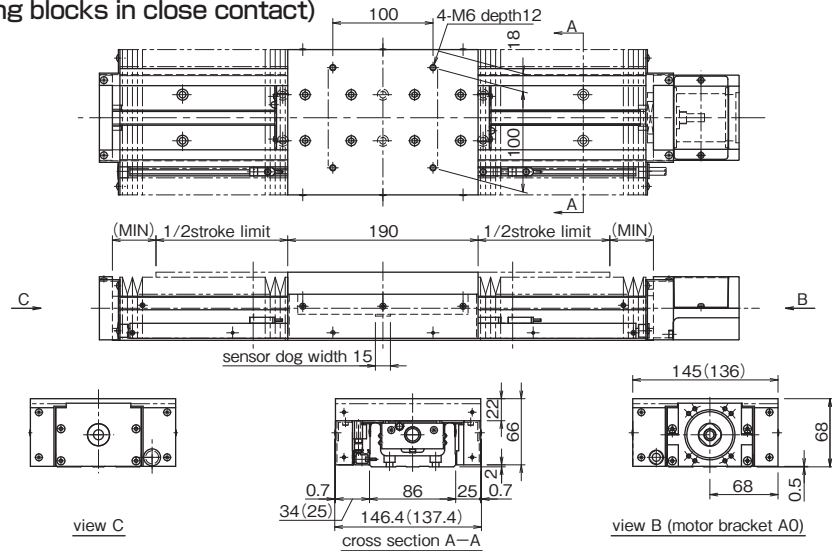

- The drawings show the "JML" configuration. The cross sections become reversed when "J *R" is selected.
- The numbers in the parentheses are the dimensions when sensors are not selected.
- Please refer to page G-26 for dimensions that are not shown on the drawings.
- material of bellows: composite resin sheet (glossy black)

rail length	L	1 long block			2 long blocks		
		stroke limit	effective stroke	MIN	stroke limit	effective stroke	MIN
340	328	192	172	33.5	97	77	26.5
440	428	272	252	43.5	183	163	33.5
540	528	364	344	47.5	263	243	43.5
640	628	450	430	54.5	355	335	47.5
740	728	530	510	64.5	441	421	54.5
840	828	608	588	75.5	521	501	64.5
940	928	686	666	86.5	599	579	75.5
1,040	1,028	774	754	92.5	677	657	86.5
1,140	1,128	866	846	96.5	765	745	92.5
1,240	1,228	944	924	107.5	857	837	96.5

* The rail mounting holes at the center cannot be used for the rail length 340 with two long blocks.

BG46

C(1 short block)

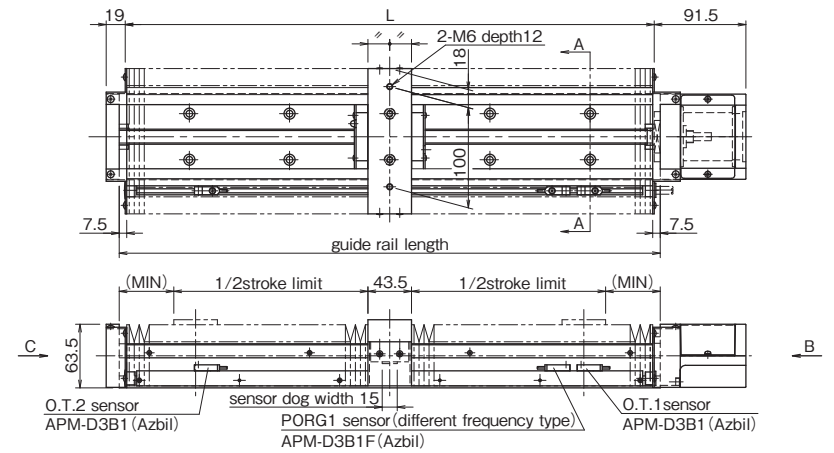

D(2 short blocks in close contact)

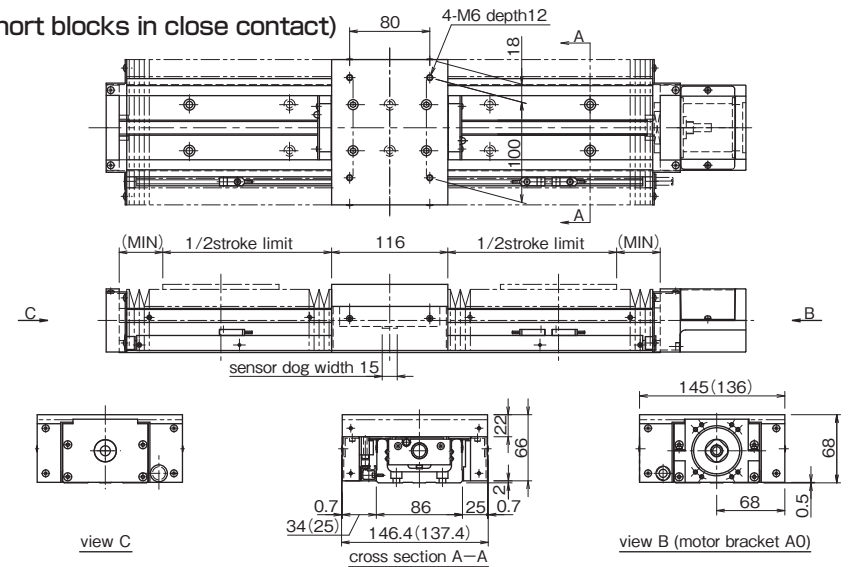

- The drawings show the "JML" configuration. The cross sections become reversed when "J *R" is selected.
- The numbers in the parentheses are the dimensions when sensors are not selected.
- Please refer to page G-28 for dimensions that are not shown on the drawings.
- material of bellows: composite resin sheet (glossy black)

rail length	L	1 short block			2 short blocks		
		stroke limit	effective stroke	MIN	stroke limit	effective stroke	MIN
340	328	219.5	199.5	38.5	165	145	29.5
440	428	309.5	289.5	43.5	247	227	38.5
540	528	387.5	367.5	54.5	337	317	43.5
640	628	467.5	447.5	64.5	415	395	54.5
740	728	545.5	525.5	75.5	495	475	64.5
840	828	645.5	625.5	75.5	573	553	75.5
940	928	723.5	703.5	86.5	651	631	86.5
1,040	1,028	803.5	783.5	96.5	751	731	86.5
1,140	1,128	881.5	861.5	107.5	831	811	96.5
1,240	1,228	981.5	961.5	107.5	909	889	107.5

* The rail mounting holes at the center cannot be used for the rail length 340 with two short blocks.

BG55

A(1 long block)

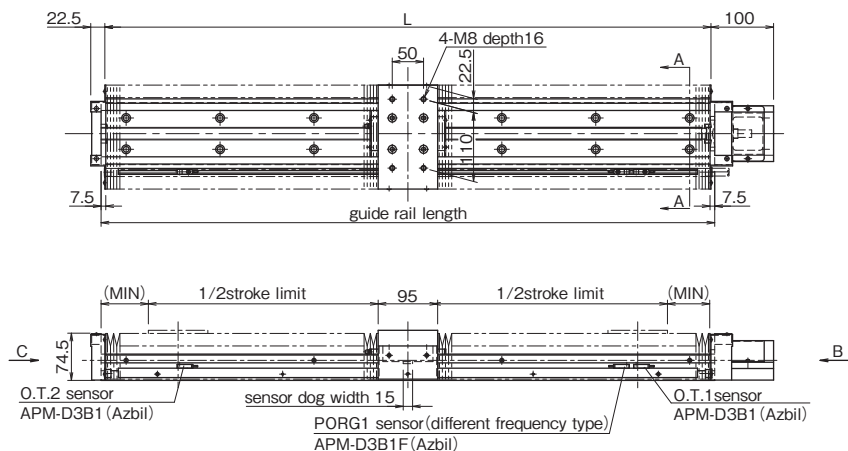

B(2 long blocks in close contact)

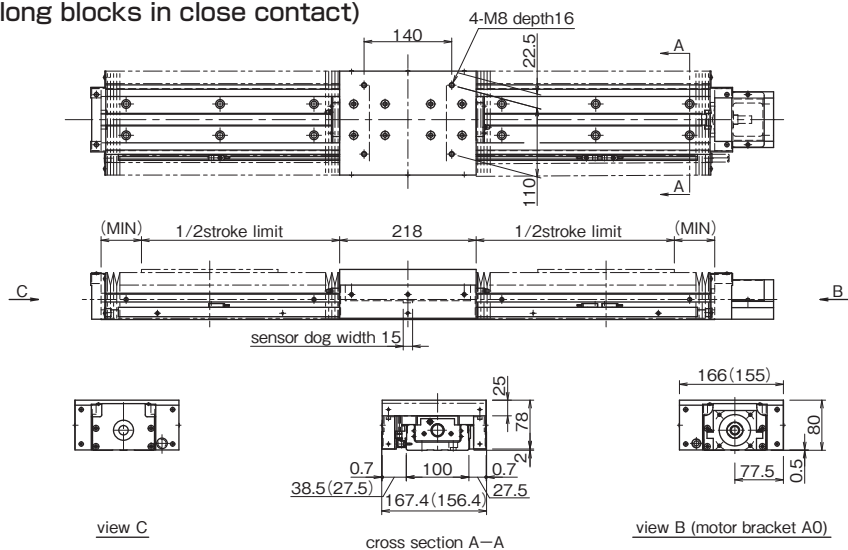

- The drawings show the "JML" configuration. The cross sections become reversed when "J *R" is selected.
- The numbers in the parentheses are the dimensions when sensors are not selected.
- Please refer to page G-30 for dimensions that are not shown on the drawings.
- material of bellows: composite resin sheet (glossy black)

rail length	L	1 long block		2 long blocks			
		stroke limit	effective stroke	MIN	stroke limit	effective stroke	MIN
980	968	734	714	75.5	633	613	64.5
1,080	1,068	812	792	86.5	711	691	75.5
1,180	1,168	912	892	86.5	789	769	86.5
1,280	1,268	992	972	96.5	889	869	86.5
1,380	1,368	1,070	1,050	107.5	969	949	96.5

SENSOR

Photomicro sensor or proximity sensor can be attached to the BG actuator with our optional sensor-mounting rail (the same length as the guide rail length). Tapped holes are machined on both sides of the guide rail, allowing attachment of sensor to either side. Standard positioning (without special instruction from customer) would be to the left of the motor mount end. Sensor option includes the items that are listed below. Three types of sensor rail are available. (see Figure G-16) For details, please refer to page G-63~73. Depending on sizes, some sensor rail are not available. (See Figure G-16)

Table G-17 NPN Sensor

sensor code	sensor type	BG15	BG20	BG26	BG33	BG46	BG55
S	slim/compact type photomicro sensor	—	PM-L25 [3pcs] ¹ (SUNX)			EE-SX674 [3pcs] ² (OMRON)	
H	close contact capable photomicro sensor					EE-SX671 [3pcs] ² (OMRON)	
K	proximity sensor (N.C.contact) ³			APM-D3B1 [2pcs] ¹ APM-D3B1F [1pc] ^{1,4} (Azbil)			

- *1 : length of cable: 1m
- *2 : 3 pcs of sensor connector EE-1001 (OMRON) will be attached
- *3 : normal close contact
- *4 : different frequency type

Figure G-16 Sensor rail

sensor rail No.	sensor rail 1	sensor rail 2	sensor rail 3
	part number		
BG15	○	×	×
BG20	○	×	×
BG26	○	×	×
BG33	○	○	○
BG46	○	○	○
BG55	○	○	○

Symbols for without sensor

[N] after sensor code option indicates with sensor parts except for sensor. Sensor rail and sensor dog according to sensor code are attached.

sensor code	S	H	K	SN	HN	KN
sensors (and sensor connectors)	○	○	○	×	×	×
sensor rail (and sensor mounting plates)	○	○	○	○	○	○
sensor dog	○	○	○	○	○	○

Notes The sensor mounting plates are also provided when needed. The sensor mounting plates are mounted on the sensor rail when shipping. Screw for mounting sensor is not provided.

BG15

K Specification (Proximity Sensor)

—Without Top Cover—

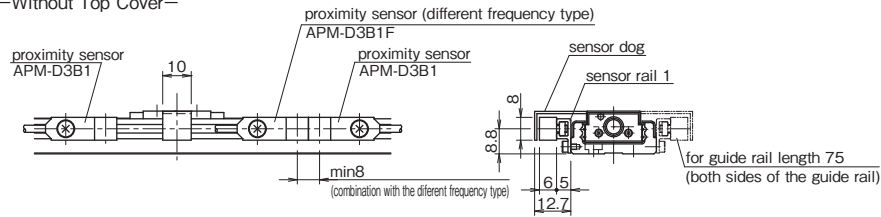

—With Top Cover—

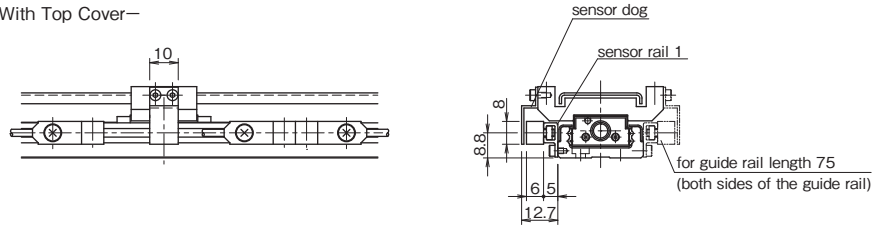

Accessories

part name	qty
proximity sensor: APM-D3B1 (Azbil)	2 pcs
proximity sensor (different frequency type): APM-D3B1F (Azbil)	1 pc
sensor rail 1	1 pc
sensor dog	1 pc

*2 pcs of sensor dogs for BG15A-75 (refer to the figure on the right.)

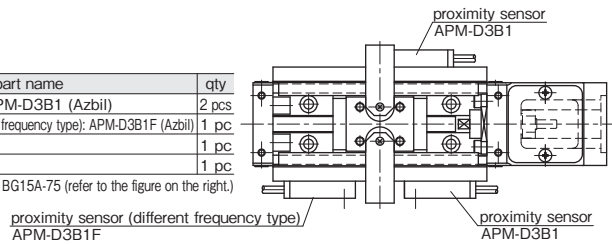

BG20

S Specification (Compact Photomicro Sensor)

—Without Top Cover—

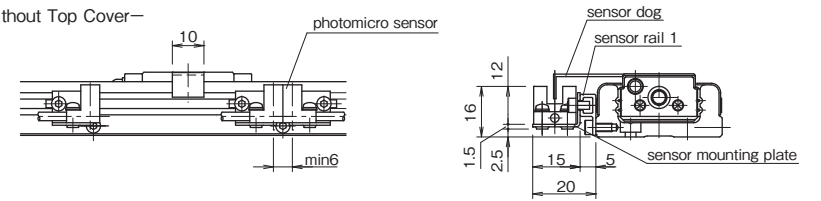

—With Top Cover—

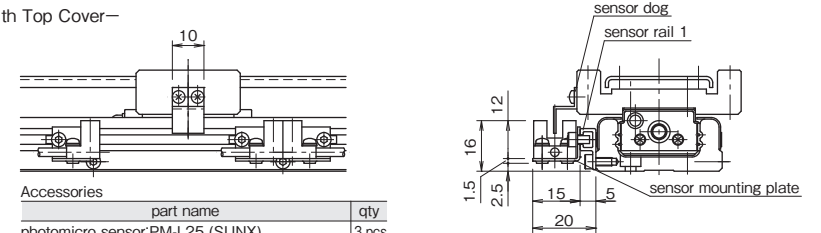

Accessories

part name	qty
photomicro sensor: PM-L25 (SUNX)	3 pcs
sensor mounting plate	3 pcs
sensor rail 1	1 pc
sensor dog	1 pc

K Specification (Proximity Sensor)

—Without Top Cover—

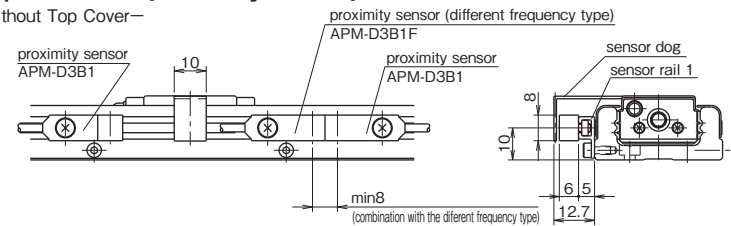

—With Top Cover—

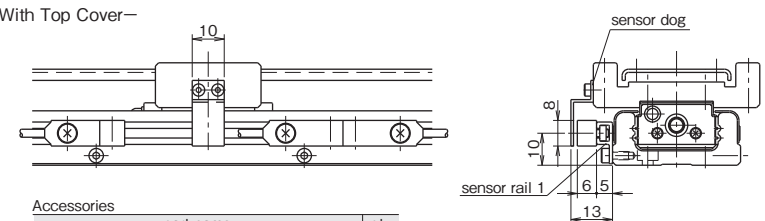

Accessories

part name	qty
proximity sensor: APM-D3B1 (Azbil)	2 pcs
proximity sensor (different frequency type): APM-D3B1F (Azbil)	1 pc
sensor rail 1	1 pc
sensor dog	1 pc

BG26

S Specification (Compact Photomicro Sensor)

—Without Top Cover—

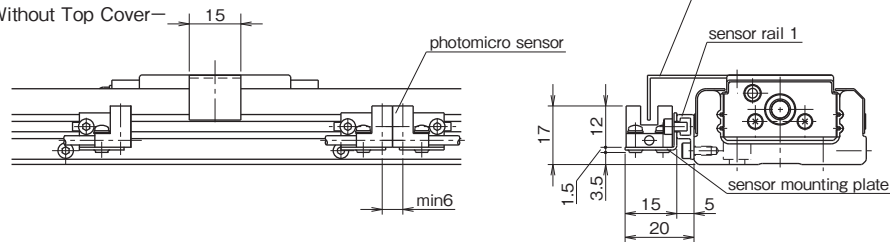

—With Top Cover—

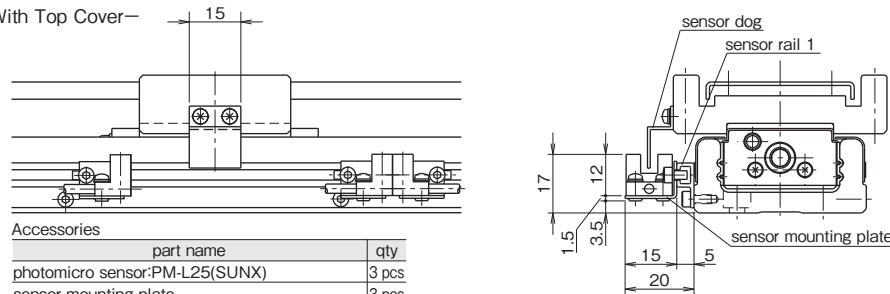

Accessories

part name	qty
photomicro sensor:PM-L25(SUNX)	3 pcs
sensor mounting plate	3 pcs
sensor rail 1	1 pc
sensor dog	1 pc

K Specification (Proximity Sensor)

—Without Top Cover—

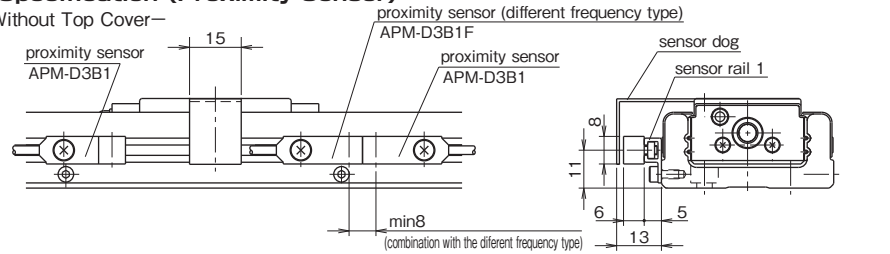

—With Top Cover—

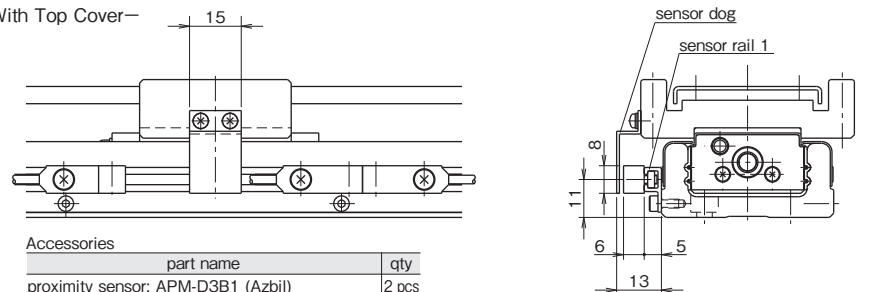

Accessories

part name	qty
proximity sensor: APM-D3B1 (Azbil)	2 pcs
proximity sensor (different frequency type):APM-D3B1F(Azbil)	1 pc
sensor rail 1	1 pc
sensor dog	1 pc

BG33

S Specification (Slim-Type Photomicro Sensor)

—Without Top Cover—

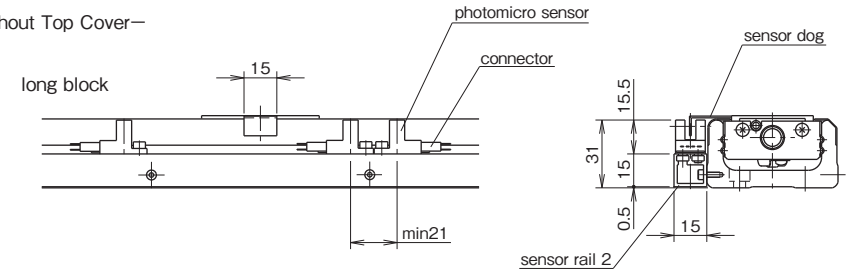

long block

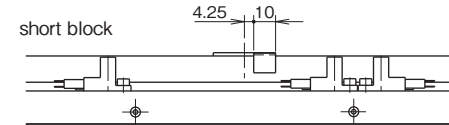

—With Top Cover—

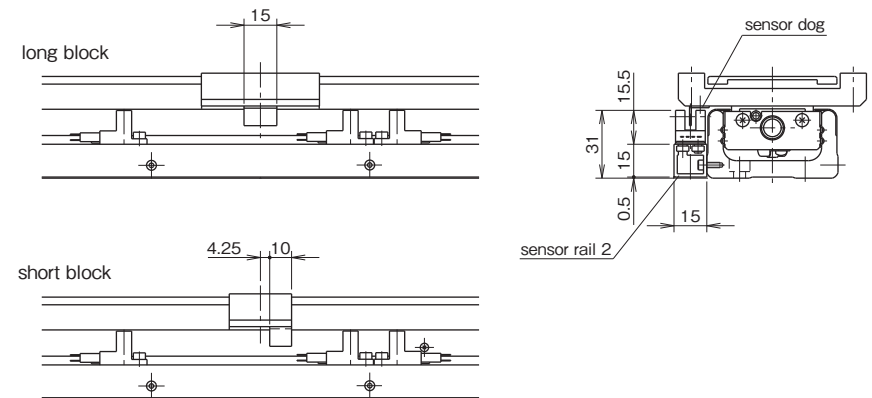

long block

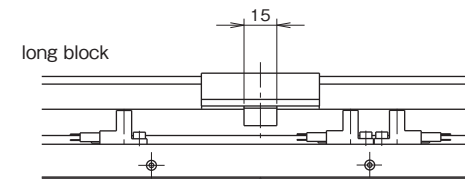

short block

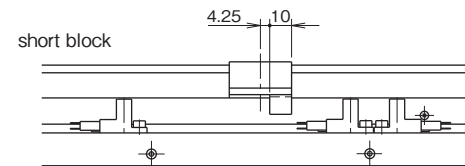

Accessories

part name	qty
photomicro sensor: EE-SX674 (OMRON)	3 pcs
connector: EE-1001 (OMRON)	3 pcs
sensor rail 2	1 pc
sensor dog	*1 pc

*2 pcs for BG33D-150.

BG33

H Specification (Close Contact Capable Photomicro Sensor)

—Without Top Cover—

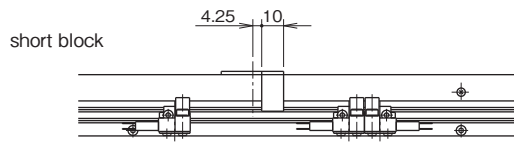
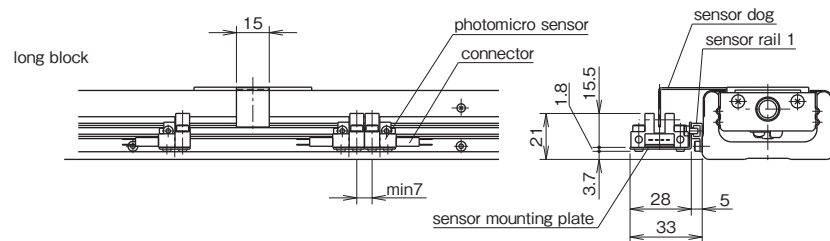

—With Top Cover—

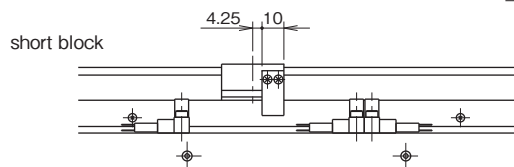
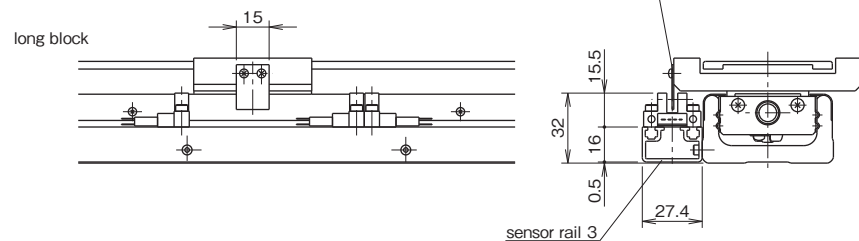

Accessories

part name	qty
photomicro sensor: EE-SX671 (OMRON)	3 pcs
connector: EE-1001 (OMRON)	3 pcs
sensor mounting plate (only for the without cover type)	3 pcs
sensor rail 1 or 3	1 pc
sensor dog	*1 pc

*2 pcs for BG33D-150.

BG33

K Specification (Proximity Sensor)

—Without Top Cover—

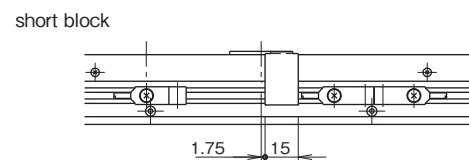
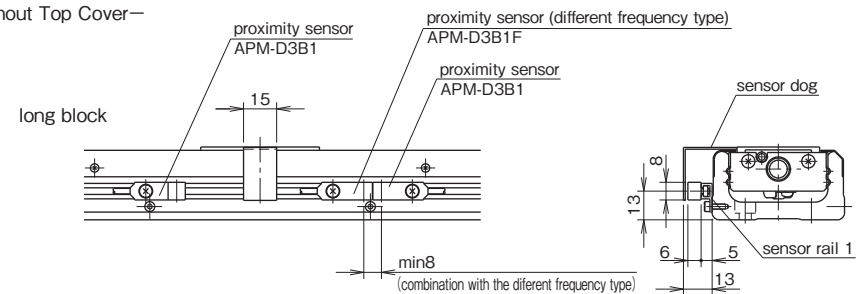

—With Top Cover—

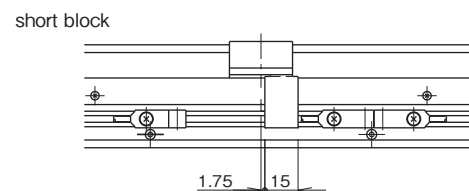
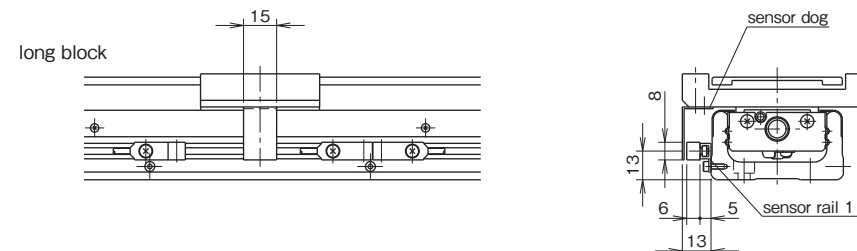

Accessories

part name	qty
proximity sensor: APM-D3B1 (Azbil)	2 pcs
proximity sensor (different frequency type): APM-D3B1F (Azbil)	1 pc
sensor rail 1	1 pc
sensor dog	*1 pc

*2 pcs for BG33D-150.

BG46

S Specification (Slim-Type Photomicro Sensor)

—Without Top Cover—

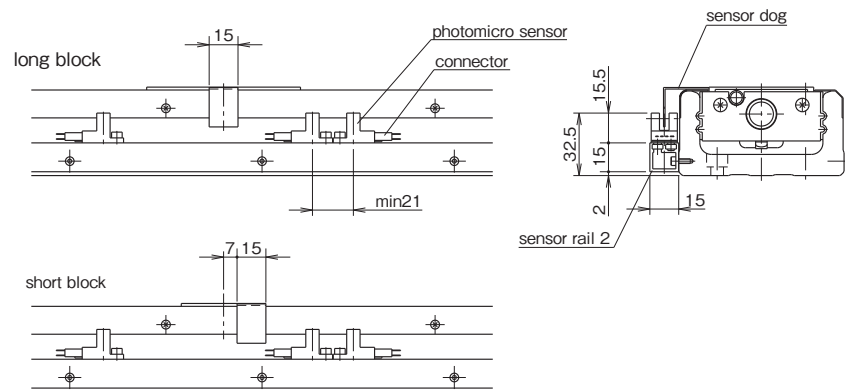

—With Top Cover—

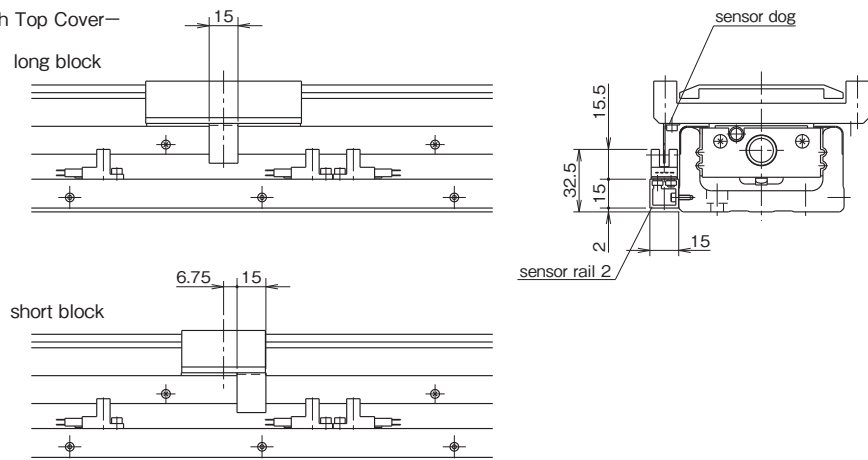

Accessories

part name	qty
photomicro sensor:EE-SX674 (OMRON)	3 pcs
connector: EE-1001 (OMRON)	3 pcs
sensor rail 2	1 pc
sensor dog	1 pc

BG46

H Specification (Close Contact Capable Photomicro Sensor)

—Without Top Cover—

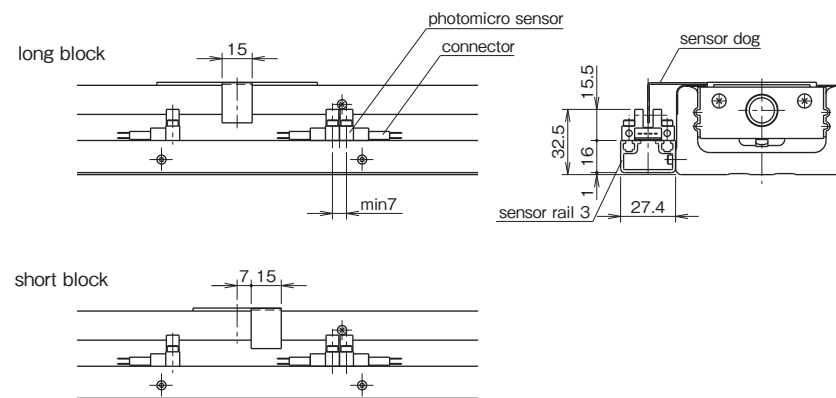

—With Top Cover—

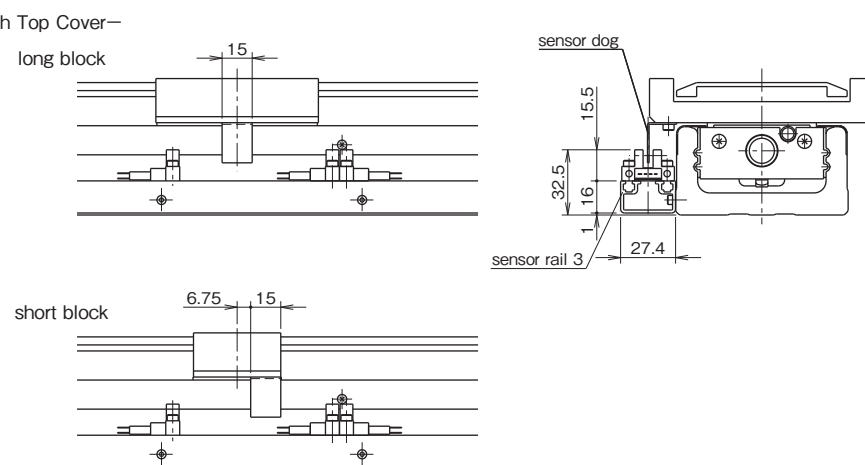

Accessories

part name	qty
photomicro sensor: EE-SX671 (OMRON)	3 pcs
connector: EE-1001 (OMRON)	3 pcs
sensor rail 3	1 pc
sensor dog	1 個

BG46

K Specification (Proximity Sensor)

—Without Top Cover—

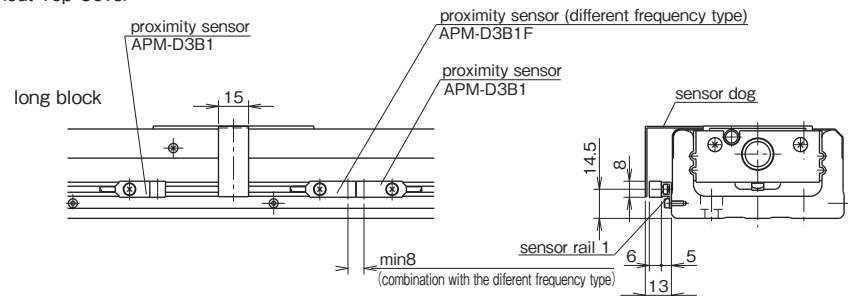

short block

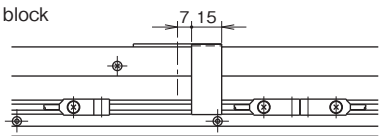

—With Top Cover—

long block

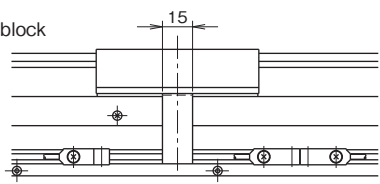

short block

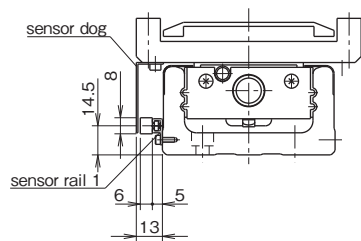
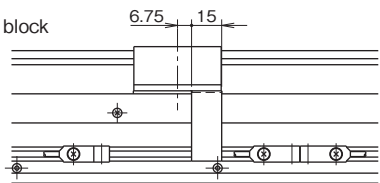

Accessories

part name	qty
proximity sensor: APM-D3B1 (Azbil)	2 pcs
proximity sensor (different frequency type): APM-D3B1F (Azbil)	1 pc
sensor rail 1	1 pc
sensor dog	1 pc

BG55

S Specification (Slim-Type Photomicro Sensor)

—Without Top Cover—

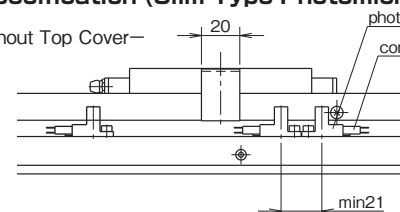

—With Top Cover—

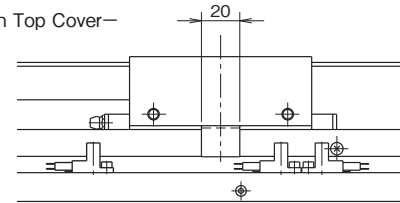

Accessories

part name	qty
photomicro sensor: EE-SX674 (OMRON)	3 pcs
connector: EE-1001 (OMRON)	3 pcs
sensor rail 2	1 pc
sensor dog	1 pc

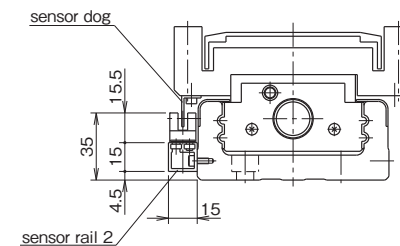
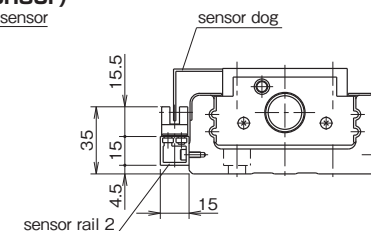

H Specification (Close Contact Capable Photomicro Sensor)

—Without Top Cover—

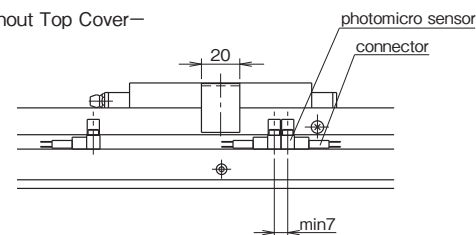

—With Top Cover—

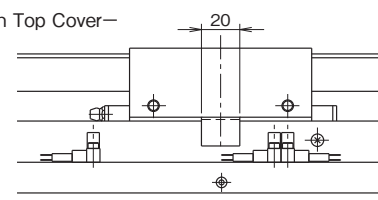

Accessories

part name	qty
photomicro sensor: EE-SX671 (OMRON)	3 pcs
connector: EE-1001 (OMRON)	3 pcs
sensor rail 3	1 pc
sensor dog	1 pc

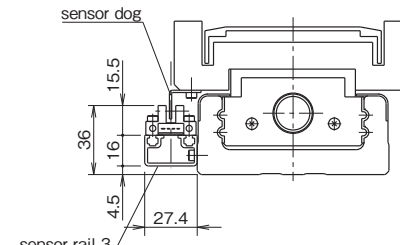
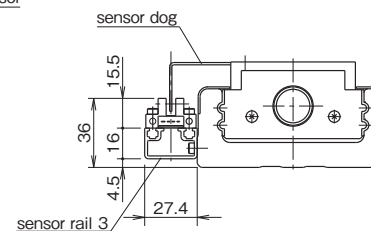

BG55

K Specification (Proximity Sensor)

—Without Top Cover—

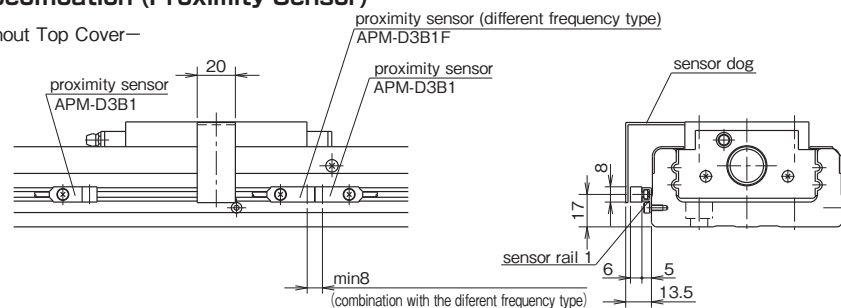

—With Top Cover—

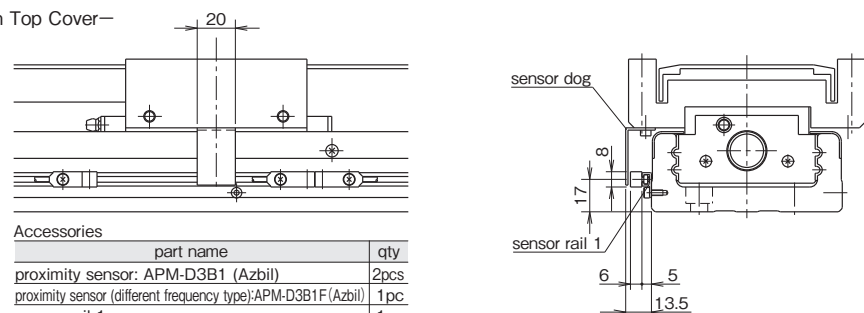

Accessories	
part name	qty
proximity sensor: APM-D3B1 (Azbil)	2pcs
proximity sensor (different frequency type):APM-D3B1F (Azbil)	1pc
sensor rail 1	1pc
sensor dog	1pc

PNP SENSOR

BG type sensors can be changed to the PNP type by adding a sensor option code "PNP" at the end of the part number. Refer to Table G-18 for the model number of PNP type sensors.

Table G-18 Standard (PNP) Sensor

sensor symbol	sensor type	BG15	BG20	BG26	BG33	BG46	BG55
S	slim/compact type photomicro sensor	—	PM-L25-P [3 pcs] ^{*1} (SUNX)	—	—	EE-SX674P [3 pcs] ^{*2} (OMRON)	—
H	close contact capable photomicro sensor	—	—	—	—	EE-SX671P [3 pcs] ^{*2} (OMRON)	—
K	proximity sensor (N.C. contact) ^{*3}	—	APM-D3E1 [2 pcs] ^{*1} APM-D3E1F [1 pc] ^{*1,4} (Azbil)	—	—	—	—

*1: length of cable: 1m
 *2: 3 pcs of connector EE-1001 (OMRON) will be attached
 *3: normal close contact
 *4: different frequency type

POSITIONING PIN HOLE

For the BG type, positioning pin holes can be provided on the slide block and sub table by adding the option code "PS" or "PW" in the end of the part number. The option code "PR" is used to provide the guide rail with positioning pin holes. When positioning pin holes are necessary on both the slide block/sub table and guide rail, please add the option code "PSR" or "PWR".

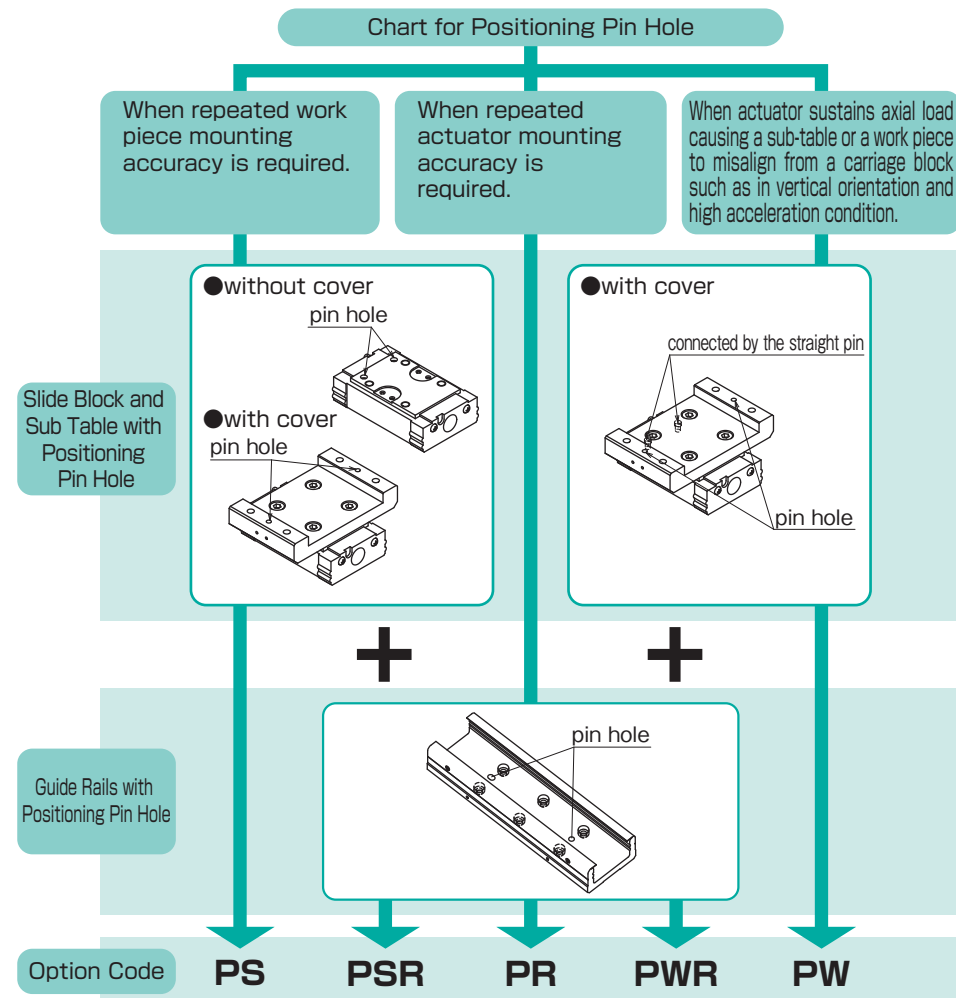

Positioning Pin Hole for Slide Block and Sub Table

It is useful when exacting reassembly positioning is required. In case of two blocks used, both blocks are processed. When the code "PS" is specified, the drilling hole is processed only on the mounting surface (slide block or sub table). When the code "PW" is specified for a BH with a top cover, the slide block and sub table are connected by the straight pins at the location where the "PS" option specifies on the slide block. Note that NB does not supply straight pins for the "PS" option. Also NB can provide positioning pin holes with bellows. Please contact NB for details.

BG15A,B (long block)

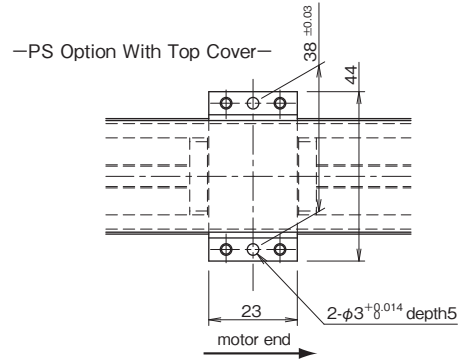

*Please contact NB for the without-top-cover option or the "PW" option.

BG20A,B (long block)

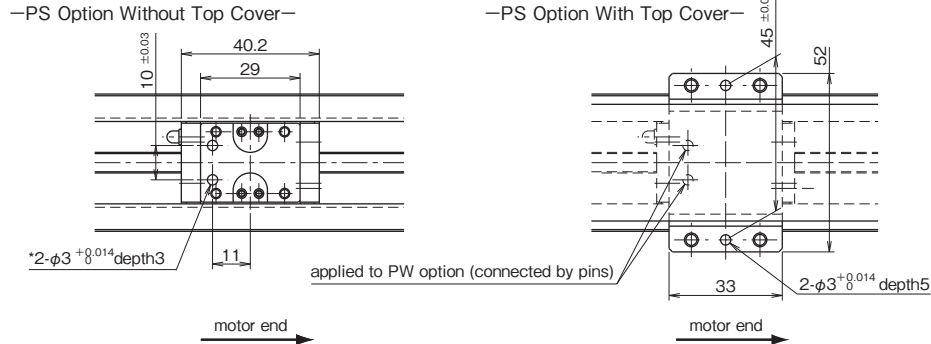

For some cases, a shallow counterbore of $\phi 4$ will be machined at the hole area with "" to remove a hardened layer.

BG26A,B (long block)

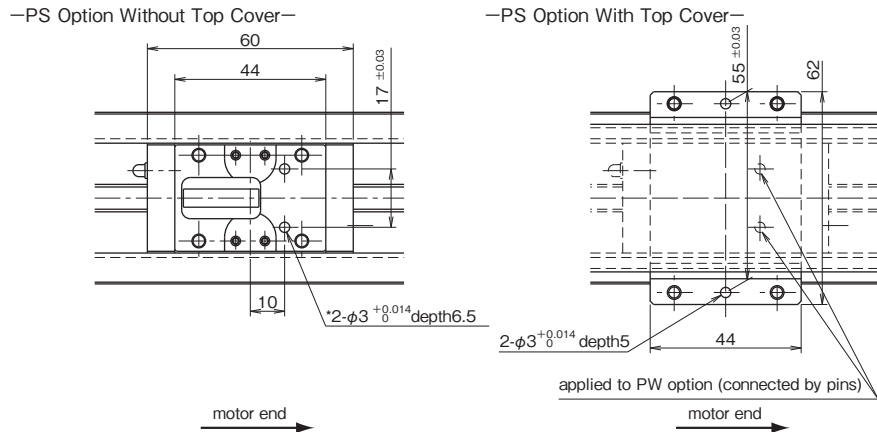

For some cases, a shallow counterbore of $\phi 4$ will be machined at the hole area with "" to remove a hardened layer.

BG33A,B (long block)

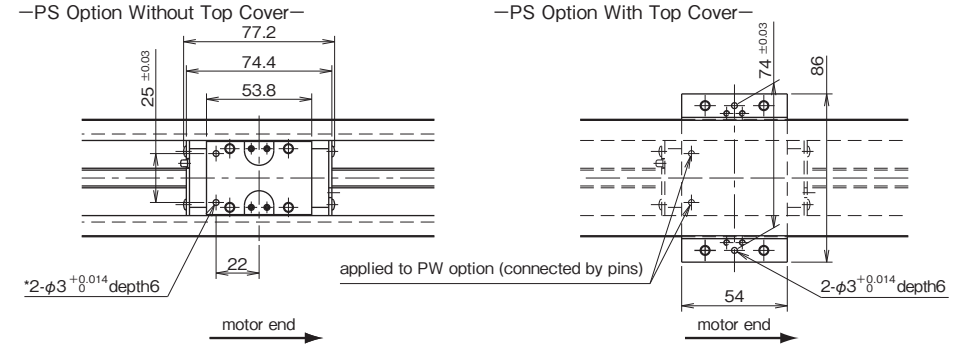

For some cases, a shallow counterbore of $\phi 4$ will be machined at the hole area with "" to remove a hardened layer.

BG33C,D (short block)

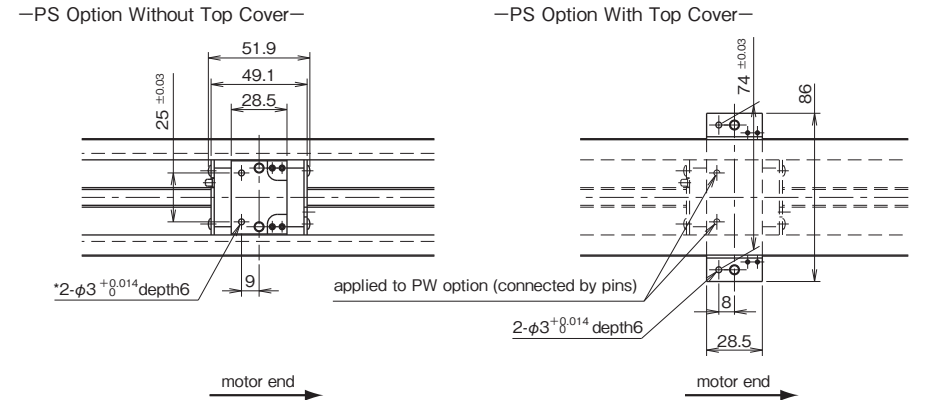

For some cases, a shallow counterbore of $\phi 4$ will be machined at the hole area with "" to remove a hardened layer.

BG46A,B (long block)

—PS Option Without Top Cover—

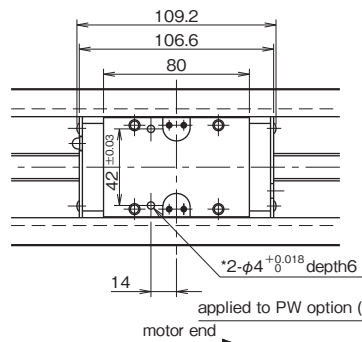

—PS Option With Top Cover—

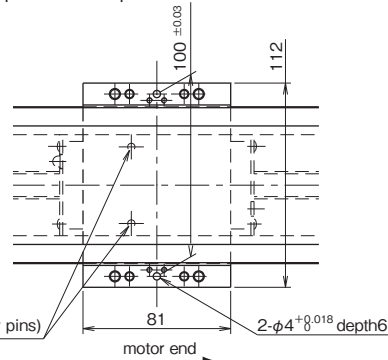

For some cases, a shallow counterbore of $\phi 5$ will be machined at the hole area with "" to remove a hardened layer.

BG46C,D (short block)

—PS Option Without Top Cover—

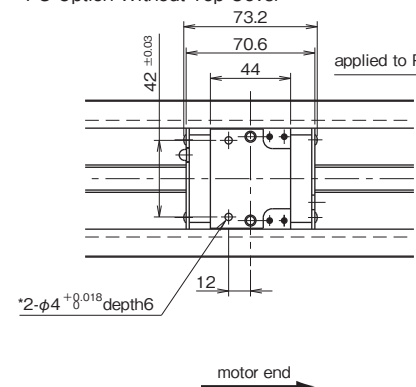

—PS Option With Top Cover—

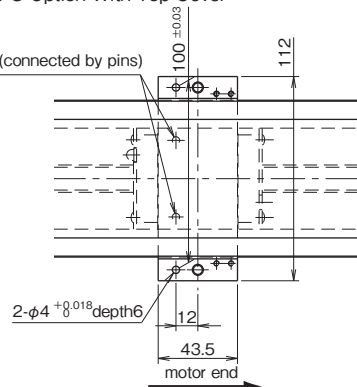

For some cases, a shallow counterbore of $\phi 5$ will be machined at the hole area with "" to remove a hardened layer.

BG55A,B (long block)

—PS Option Without Top Cover—

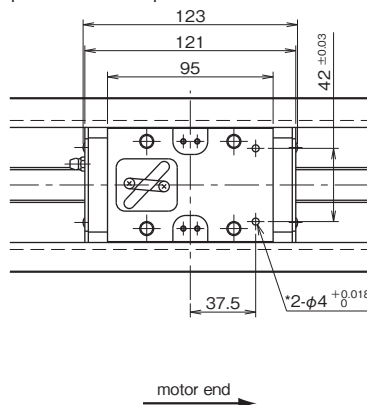

—PS Option With Top Cover—

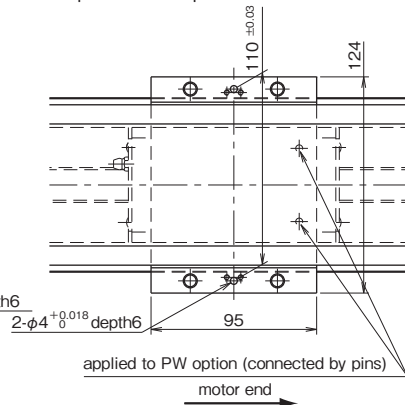

For some cases, a shallow counterbore of $\phi 5$ will be machined at the hole area with "" to remove a hardened layer.

POSITIONING PIN HOLE FOR GUIDE RAIL

It is useful to use positioning pin holes on the guide rail when exacting reassembly positioning is required. NB does not supply straight pins. (JIS B1354-1988 parallel pin type A is recommended.) After the insertion of the straight pins in the guide rail base, the pins might interfere with the slide block. In the positioning process, please consider the base thickness. The length of the pin in the base shall be shorter than the base thickness. Please make sure that the pins shall not interfere with the slide block.

Figure G-17 Positioning Pin Hole Location

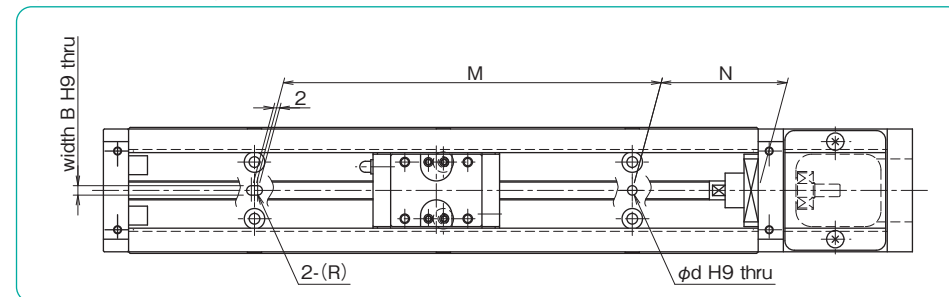

Table G-19 Positioning Pin Hole for Guide Rail

unit: mm

part number	pin length (base thickness)	major dimensions				ϕd	B
		rail length	N	M			
BG15	3.5 or less	75	12.5	50	$\phi 3^{+0.025}_0$	$3^{+0.025}_0$	
		100	25				
		125	12.5				
		150	25				
		175	12.5				
BG20	4.5 or less	200	25	150			
		100	20	60			
		150	15	120			
BG26	6 or less	200	40	120			
		150	35	80			
		250	45	160			
BG33	8 or less	300	30	240			
		150	25	100			
		200	50	200			
		300		300			
		400		400			
BG46	11 or less	500	70	500	$\phi 5^{+0.030}_0$	$5^{+0.030}_0$	
		600		500			
		340		200			
		440		300			
		540		400			
		640		500			
		740		600			
		840		700			
		940		800			
		1,040		900			
1,140	1,000						
1,240	1,100						
BG55	13 or less	980	40	900	$\phi 6^{+0.030}_0$	$6^{+0.030}_0$	
		1,080	15	1,050			
		1,180	65				
		1,280	40	1,200			
		1,380	15	1,350			

LUBRICATION

- BG type contains a lithium soap based grease. (Multemp PS No.2, KYODO YUSHI) Apply similar type of grease for the lubrication as required depending on the operating conditions.
- Use the grease fitting to lubricate the slide block. For ball screw portion apply grease directly to the surface of screw shaft. BG15 slide block has $\phi 2\text{mm}$ oil holes instead of grease fitting.
- Unless otherwise instructed, a grease fitting is located as shown in Figure G-18.
- The grease can be changed to a high function type by adding a special grease option at the end of the part number. Please refer to Table G-20 for the grease type. Also refer to page Eng-51 for further details.

Table G-20 Applicable Grease

grease option	features	product name
none (standard)	—	Multemp PS No.2 (KYODO YUSHI)
GU	urea-type low dust generation grease; low sliding resistance	KGU Grease
GLA	lithium-type low dust generation grease	KGLA Grease
GF	urea-type anti-fretting grease	KGF Grease

Figure G-18 Location of Grease Fitting

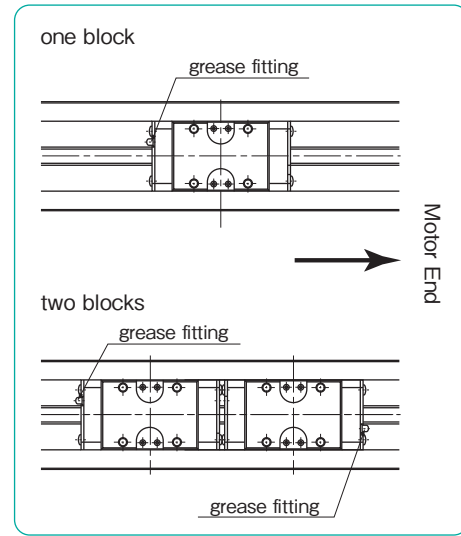

Two Axes Combined Bracket

NB provides optional brackets to combine two axes for BG20, 26, 33, 46 series. Each axis is available with one long block with top cover type only. Other combination can be available, please contact NB for details.

Combination Examples

Horizontal - Horizontal

- Type A
Upper Axis: Fixed Rail, Moving Block

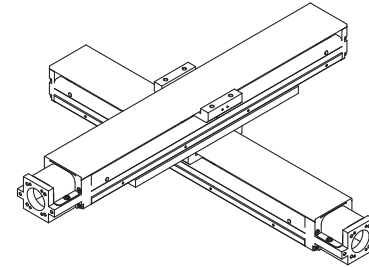

- Type B
Upper Axis: Fixed Block, Moving Rail

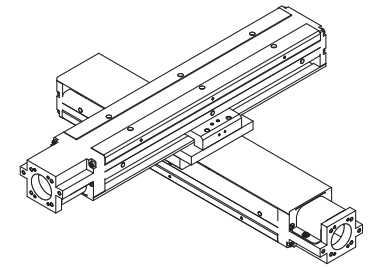

Horizontal - Sideway

- Type C
Upper Axis: Fixed Rail, Moving Block

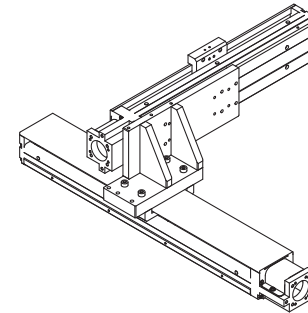

- Type D
Upper Axis: Fixed Block, Moving Rail

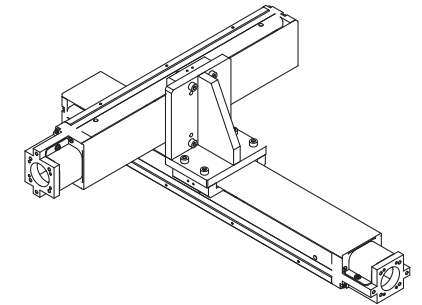

Horizontal - Vertical

- Type E
Upper Axis: Fixed Rail, Moving Block

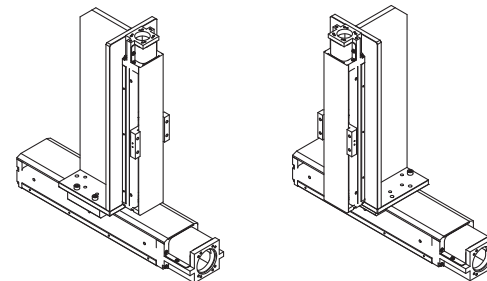

BH TYPE

PART NUMBER STRUCTURE

Part number for BH type is described as follows.

①	②	③	④	⑤	⑥	⑦	⑧	⑨	⑩
BH	15	01	A	100	U	A0			G▲
		02	B	150	W	A1	C	K	LB
				200		A2			PNP
						A3			

①	②	③	④	⑤	⑥	⑦	⑧	⑨	⑩
BH	23	02	A	150	U	A0			P△□
		05	B	200	W	A1	C	S	G▲
				250		A3		K	LB
				300		A5			PNP
						A6			

①	②	③	④	⑤	⑥	⑦	⑧	⑨	⑩
BH	30	04	A	150	U	A0			
		05	B	200	W	A1	C	S	P△□
		10		300		A2		K	G▲
				400		A3			LB
				500		A4			PNP
				600		A5			
				700		A7			
				750		B1			
						RO			
						RA□			
						RB□			

*Guide rail length 750mm is only available for BH3010.

①	②	③	④	⑤	⑥	⑦	⑧	⑨	⑩
BH	45	05	A	340	U	A0			
		10	B	440	W	A1	C	S	P△□
		20	C	540		A2		K	G▲
			D	640		A3			LB
				740		A4			PNP
				840		A5			
				940		A6			
						RO			
						RA□			
						RB□			
						RC□			

- ① BH type
- ② size
- ③ ballscrew lead (refer to page G-84)
- ④ type of block

A: 1 long block

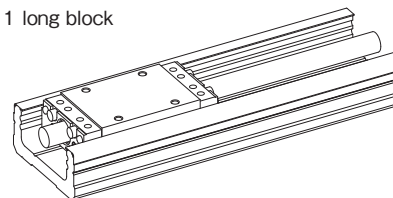

B: 2 long blocks

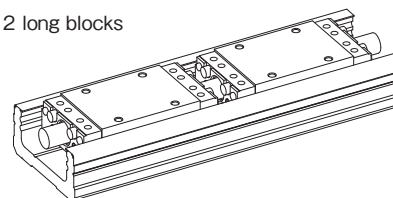

C: 1 short block

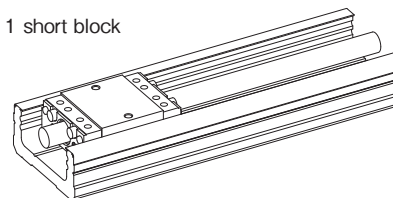

D: 2 short blocks

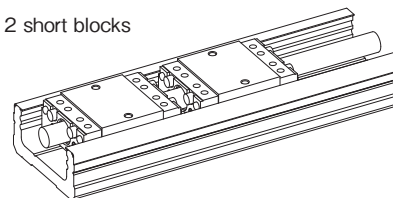

⑧ cover

none: without top cover
(refer to page G-88~)

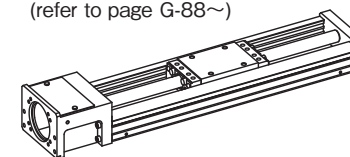

C: with top cover + sub table
(refer to page G-89~)

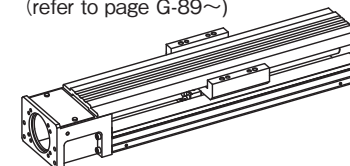

⑨ sensor (refer to page G-111~)

none	without sensor
S	with slim-type / compact photomicro sensor
K	with proximity sensor

⑩ option

none	without option
P△□	with positioning pin hole (*1)
G▲	with special grease option (*2)
LB	with low temperature black chrome treatment (*3)
PNP	with PNP sensor

In case of multiple options, add + between each option.
Example: (PS + LB + PNP)

*1: △ is S, W or R (refer to page G-118)
□ is R (refer to page G-118)

*2: ▲ is U, L or F (refer to page G-122)
Grease is applied to slide guide, ballscrew, and angular bearings.

*3: LB is applied to steel parts except for aluminum parts and radial bearings.

*Drive block is located closest to motor bracket side.

⑤ guide rail length

⑥ accuracy grade (refer to page G-86)

U	positioning repeatability $\pm 5 \mu\text{m}$
W	positioning repeatability $\pm 10 \mu\text{m}$

⑦ motor bracket (refer to page G-98, 99)

The number in the square □ after suffix RA, RB or RC indicates the mounting direction code.
(refer to page G-108, 109)

SPECIFICATIONS

BH Type is categorized as either positioning repeatability $\pm 5\mu\text{m}$ (U) or positioning repeatability $\pm 10\mu\text{m}$ (W).

Table G-21 Specifications

part number			BH1501	BH1502	BH2302	BH2305	BH3004	BH3005	BH3010	BH4505	BH4510	BH4520		
accuracy grade			W	U	W	U	W	U	W	U	W	U		
guide	long block	radial clearance	μm		-3 ~ 0		-3 ~ 0		-3 ~ 0		-5 ~ 0			
		basic dynamic load	C	kN		1.6		4.3		7.0		27.0		
	basic static load	C ₀	kN		2.7		7.0		11.8		45.0			
	allowable static moment	M	M _P	N·m		10		46		101		572		
			M _{2P}	N·m		60		276		606		3,432		
			M _Y	N·m		11		51		120		681		
			M _{2Y}	N·m		71		306		720		4,086		
			M _R	N·m		28		134		260		1,410		
			M _{2R}	N·m		56		268		520		2,820		
	short block	basic dynamic load	C	kN								16.9		
			C ₀	kN								28.1		
		allowable static moment	M	M _P	N·m		-		-		-		223	
				M _{2P}	N·m		-		-		-		1,341	
				M _Y	N·m		-		-		-		266	
M _{2Y}				N·m		-		-		-		1,598		
M _R	N·m		-		-		-		887					
M _{2R}	N·m		-		-		-		1,774					
ball screw	shaft diameter		mm		6		8		10		15			
	lead		mm		1	2	2	5	4	5	10	20		
	basic dynamic load	C _a	kN		0.39	0.54	1.8	1.9	3.0	3.0	2.0	5.1	5.1	3.1
	basic static load	C _{0a}	kN		0.77	0.76	3.2	3.1	5.3	5.3	3.2	10.5	10.5	6.6
bearing support	part number		-		604 or equivalent		AC6-16DF or equivalent		708DFP5 or equivalent		5201A or equivalent			
	basic dynamic load	C _b	kN		0.5		1.79		4.40		5.90			
	basic static load	C _{0b}	kN		0.19		1.76		4.36		3.20			

M_{2P}, M_{2Y} and M_{2R} are the allowable static moments when 2 blocks are used in close contact.

Figure G-19 Direction of Moment

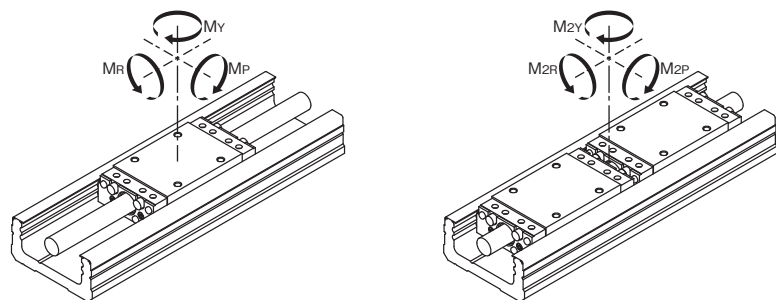

ALLOWABLE SPEED AND STROKE LIMIT

Allowable speed of BH type is subject to the type of motor and operating conditions. The speed may also be limited by the critical speed of the ballscrew. Use caution when operating at high speeds or using long rails.

Table G-22 Allowable Speed and Stroke Limit

part number	rail length	stroke limit (mm)				allowable speed (mm/sec)		
		1 long block	2 long blocks	1 short block	2 short blocks	lead1	lead2	
BH15	100	60	-	-	-	133	260	
	150	110	70	-	-	90	180	
	200	160	120	-	-			
part number	rail length	stroke limit (mm)				allowable speed (mm/sec)		
		1 long block	2 long blocks	1 short block	2 short blocks	lead2	lead5	
BH23	150	76	-	-	-	200	490	
	200	126	57	-	-			
	250	176	107	-	-			
	300	226	157	-	-			
part number	rail length	stroke limit (mm)				allowable speed (mm/sec)		
		1 long block	2 long blocks	1 short block	2 short blocks	lead4	lead5	lead10
BH30	150	60	-	-	-			
	200	110	-	-	-			
	300	210	126	-	-	320	400	810
	400	310	226	-	-			
	500	410	326	-	-			
	600	510	426	-	-	240	300	600
	700	610	526	-	-	170	210	430
750	660	576	-	-	-	-	380	
Guide rail length 750mm is only available for lead10.								
part number	rail length	stroke limit (mm)				allowable speed (mm/sec)		
		1 long block	2 long blocks	1 short block	2 short blocks	lead5	lead10	lead20
BH45	340	219	104	249	164			
	440	319	204	349	264			
	540	419	304	449	364	260	520	1,040
	640	519	404	549	464			
	740	619	504	649	564			
	840	719	604	749	664			
	940	819	704	849	764	200	410	830

Figure G-20 Guide Rail Length and Allowable Speed

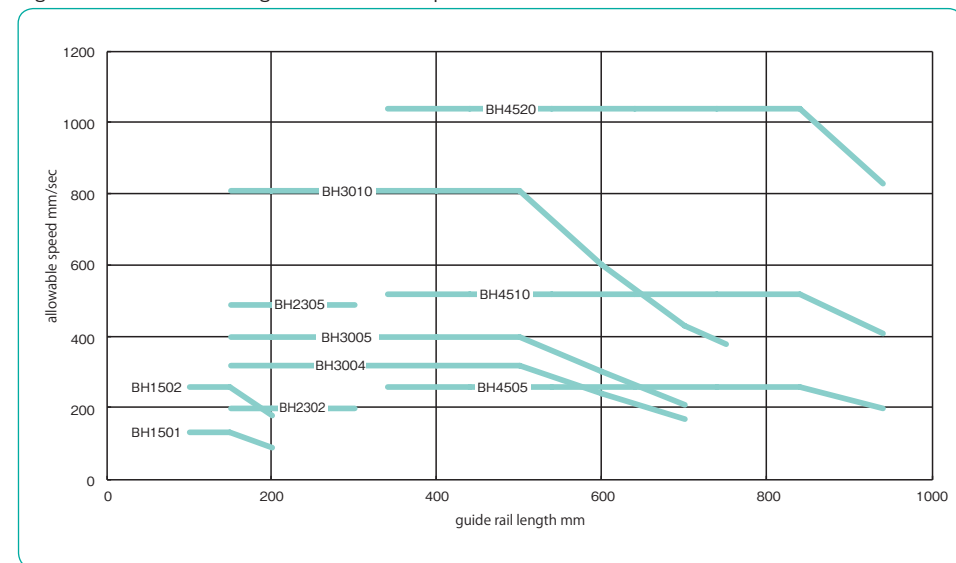

ACCURACY

Table G-23 shows accuracy of BH type.

Table G-23 Accuracy

part number	rail length mm	positioning repeatability		positioning accuracy		running parallelism B		backlash		*starting torque	
		W μ m	U μ m	W μ m	U μ m	W μ m	U μ m	W μ m	U μ m	W N · m	U N · m
BH15	100	± 10	± 5	65		15		20	5	0.010	0.012
	150			70							
	200			75							
BH23	150	± 10	± 5	70		15		20	5	0.03	0.06
	200			75							
	250			85							
	300			90							
BH30	150	± 10	± 5	70		15		20	5	0.07	0.15
	200			80							
	300			90							
	400			95							
	500			100		25		20	5	0.07	0.15
	600			110							
	700			120							
	750			130							
BH45	340	± 10	± 5	95		35		20	5	0.1	0.2
	440			100							
	540			110							
	640			120		40		20	5	0.1	0.2
	740			130							
	840			150							
	940			170							

Above values are measured by using our selected motors.

*Above specifications are based on using NB standard grease. Other grease may cause deviations.

Positioning Repeatability

After setting an arbitrary position, from one end, move the drive block to this position and measure the stop position. Repeat the positioning and measurement process 7 times with respect to the setting position at the midpoint and near both ends of travel. Take the maximum difference and divide it by 2, then indicate it with a positive and negative sign as the test result.

$$\text{Positioning Repeatability} = \pm \frac{1}{2} ((\text{maximum value of } l_n) - (\text{minimum value of } l_n))$$

Figure G-21 Positioning Repeatability

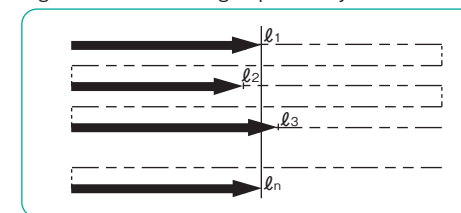

Positioning Accuracy

Positioning is performed in one direction and the resulting position is set as the datum point. Take the difference between the actual travel distance and the commanded travel distance from the datum point. Continuing in the same direction (without returning to the start point) repeat this process randomly several times until nearing to the stroke limit. Express the accuracy by the absolute maximum difference.

$$\text{Positioning Accuracy} = (\Delta l_n)_{\max}$$

Figure G-22 Positioning Accuracy

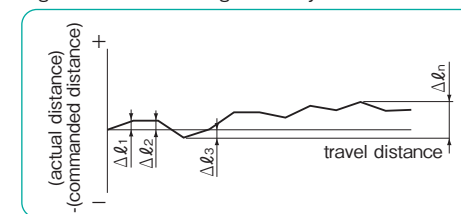

Running Parallelism B

After fixing the guide rail onto the surface plate, placing the dial test indicator on the center of the slide block and connecting the indicator probe onto the mounting surface, run the block over the entire travel distance. Take the maximum deviation in readings as the test result.

Figure G-23 Running Parallelism B

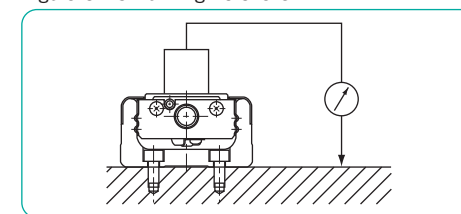

Backlash

Using the feed screw to move the slide block a little, take the dial test indicator reading and make it the datum point. While in this position, thrust the block by a certain force in the same direction without using the feed screw. Release the thrust and read the return, then take the difference from the datum point. Repeat the same process at the midpoint and near both ends of travel. Take the maximum difference as the test result.

$$\text{Backlash} = \Delta l$$

Figure G-24 Backlash

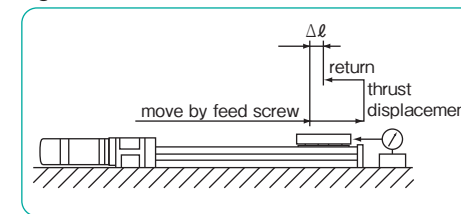

BH15 –Without Top Cover–

A(1 long block)
B(2 long blocks)

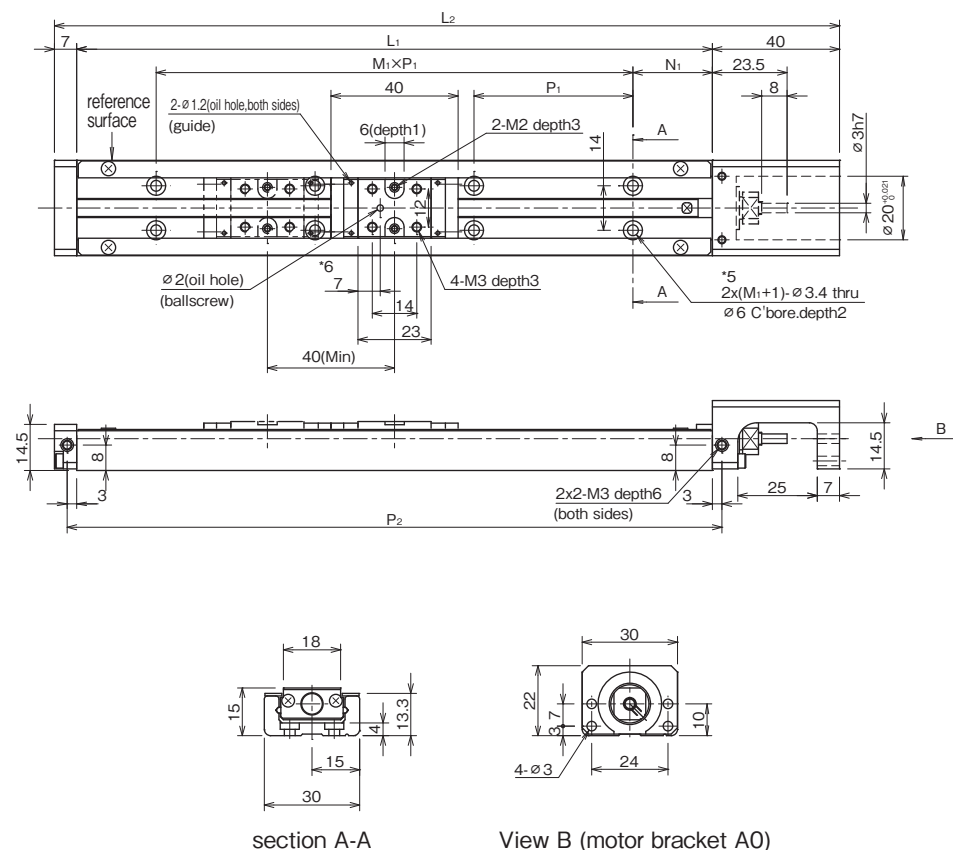

section A-A

View B (motor bracket A0)
refer to page G-102 for other motor bracket

part number ^{3,4}	stroke limit mm ¹	dimensions mm					block mass kg ²		total mass kg	
		L ₁	L ₂	N ₁	M ₁ × P ₁	P ₂	without top cover	with top cover	without top cover	with top cover
BH15 □□ A-100	60	100	147	25	1 × 50	106	0.03	0.05	0.28	0.31
B	—	—	—	—	—	—	—	—	—	—
BH15 □□ A-150	110	150	197	25	2 × 50	156	0.03	0.05	0.36	0.39
B	70						0.06	0.10	0.39	0.44
BH15 □□ A-200	160	200	247	25	3 × 50	206	0.03	0.05	0.45	0.48
B	120						0.06	0.10	0.48	0.53

*1 : Stroke limit is a drive distance between both ends of the dampers.
 *2 : Mass stated "with top cover" includes mass of sub tables.
 *3 : For B type (2 long blocks), drive block is located closest to motor bracket side.
 *4 : □ is ballscrew lead.
 *5 : For mounting guide rail, use provided hexagon socket low head cap screws. (M3x5, stainless)
 *6 : The dimension is different depending on the lead. BH1501: 7mm, BH1502: 8mm

BH15 –With Top Cover–

A(1 long block)
B(2 long blocks)

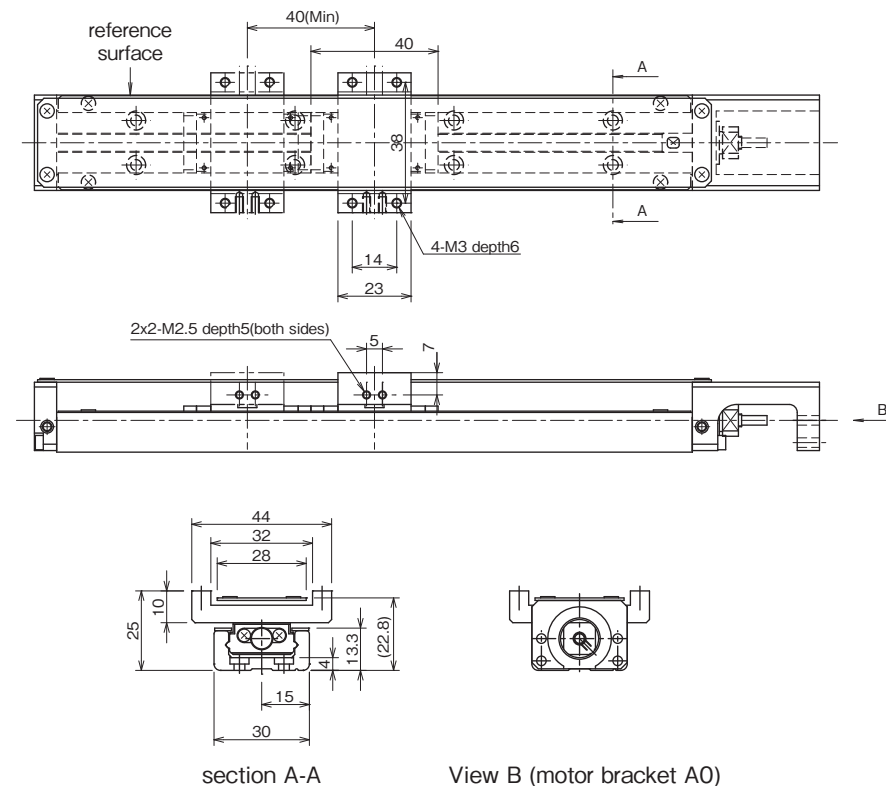

section A-A

View B (motor bracket A0)
refer to page G-102 for other motor bracket

inertia (reference values) unit : kg · m²

part number	rail length mm	long block			
		without top cover		with top cover	
		A 1 block	B 2 blocks	A 1 block	B 2 blocks
BH1501	100	1.11 × 10 ⁻⁷	—	1.20 × 10 ⁻⁷	—
	150	1.60 × 10 ⁻⁷	1.61 × 10 ⁻⁷	1.61 × 10 ⁻⁷	1.62 × 10 ⁻⁷
	200	2.10 × 10 ⁻⁷	2.11 × 10 ⁻⁷	2.11 × 10 ⁻⁷	2.12 × 10 ⁻⁷
BH1502	100	1.15 × 10 ⁻⁷	—	1.16 × 10 ⁻⁷	—
	150	1.64 × 10 ⁻⁷	1.67 × 10 ⁻⁷	1.66 × 10 ⁻⁷	1.71 × 10 ⁻⁷
	200	2.14 × 10 ⁻⁷	2.17 × 10 ⁻⁷	2.16 × 10 ⁻⁷	2.20 × 10 ⁻⁷

part name	material	remarks
guide rail	carbon steel	black oxide except for raceway grooves
ballscrew shaft	carbon steel	
slide block	chromium-molybdenum steel	
motor bracket	aluminum alloy	black anodizing
housing	aluminum alloy	black anodizing
adapter plate	aluminum alloy	black anodizing
dust cover	aluminum alloy	white anodizing
sub table	aluminum alloy	white anodizing
top cover	aluminum alloy	

When LB option is selected, steel parts are treated with low temperature black chrome treatment.

BH23 –Without Top Cover–

A(1 long block)
B(2 long blocks)

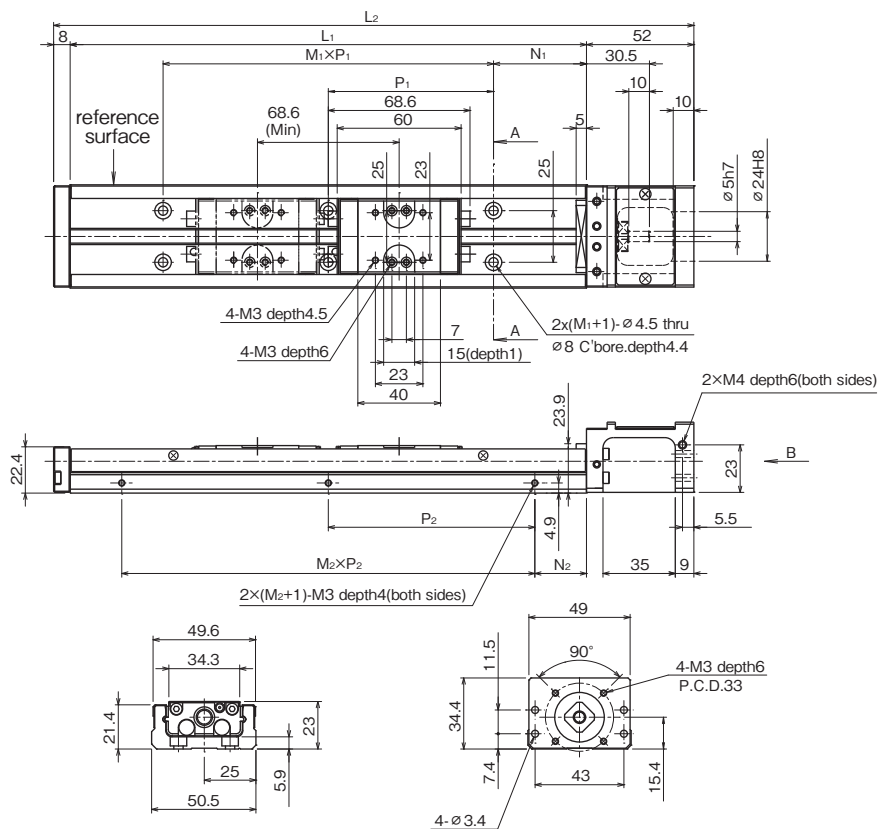

section A-A

View B (motor bracket A0)

refer to page G-103 for other motor bracket

BH23 –With Top Cover–

A(1 long block)
B(2 long blocks)

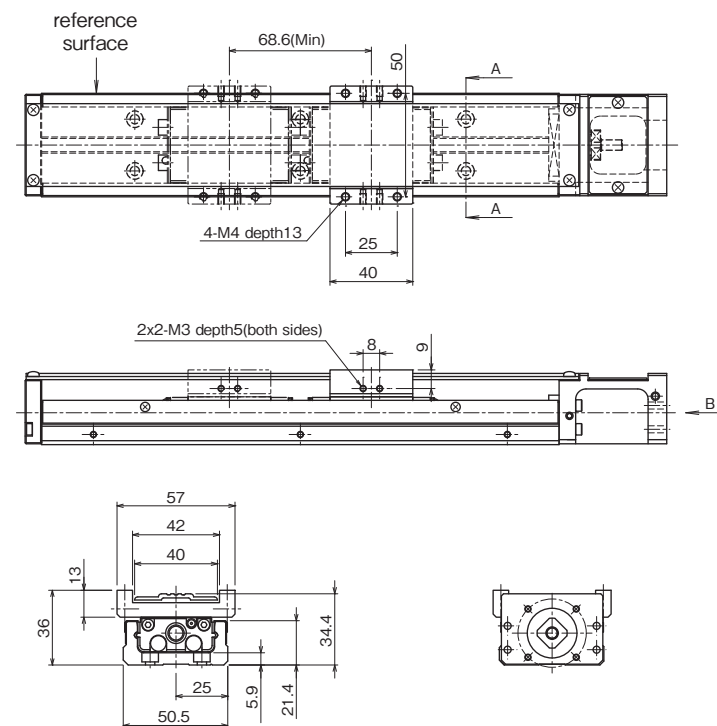

section A-A

View B (motor bracket A0)

refer to page G-103 for other motor bracket

part number ^{3,4}	stroke limit mm ¹	dimensions mm						block mass kg ²		total mass kg	
		L ₁	L ₂	N ₁	M ₁ × P ₁	N ₂	M ₂ × P ₂	without top cover	with top cover	without top cover	with top cover
BH23 □□ A-150	76	150	210	35	1 × 80	25	1 × 100	0.14	0.26	1.00	1.11
B	—	—	—	—	—	—	—	—	—	—	—
BH23 □□ A-200	126	200	260	20	2 × 80	50	1 × 100	0.14	0.26	1.21	1.32
B	57							0.28	0.52	1.35	1.46
BH23 □□ A-250	176	250	310	45		25	2 × 100	0.14	0.26	1.41	1.52
B	107							0.28	0.52	1.56	1.67
BH23 □□ A-300	226	300	360	30	3 × 80	50	2 × 100	0.14	0.26	1.61	1.73
B	157							0.28	0.52	1.76	1.88

*1: Stroke limit is a drive distance between both ends of the dampers.

*2: Mass stated "with top cover" includes mass of sub tables.

*3: For B type (2 long blocks), drive block is located closest to motor bracket side.

*4: □ is ballscrew lead.

inertia (reference values)

unit : kg · m²

part number	rail length mm	long block			
		without top cover		with top cover	
		A 1 block	B 2 blocks	A 1 block	B 2 blocks
BH2302	150	6.07 × 10 ⁻⁷	—	6.15 × 10 ⁻⁷	—
	200	7.64 × 10 ⁻⁷	7.79 × 10 ⁻⁷	7.72 × 10 ⁻⁷	7.87 × 10 ⁻⁷
	250	9.21 × 10 ⁻⁷	9.36 × 10 ⁻⁷	9.29 × 10 ⁻⁷	9.44 × 10 ⁻⁷
	300	1.08 × 10 ⁻⁶	1.09 × 10 ⁻⁶	1.09 × 10 ⁻⁶	1.10 × 10 ⁻⁶
BH2305	150	6.96 × 10 ⁻⁷	—	7.41 × 10 ⁻⁷	—
	200	8.53 × 10 ⁻⁷	9.46 × 10 ⁻⁷	8.98 × 10 ⁻⁷	9.92 × 10 ⁻⁷
	250	1.01 × 10 ⁻⁶	1.10 × 10 ⁻⁶	1.06 × 10 ⁻⁶	1.15 × 10 ⁻⁶
	300	1.17 × 10 ⁻⁶	1.26 × 10 ⁻⁶	1.21 × 10 ⁻⁶	1.31 × 10 ⁻⁶

part name	material	remarks
guide rail	carbon steel	black oxide except for raceway grooves
ballscrew shaft	carbon steel	
slide block	chromium-molybdenum steel	
motor bracket	aluminum alloy	black anodizing
coupling cover	aluminum alloy	black anodizing
housing	aluminum alloy	black anodizing
adapter plate	aluminum alloy	black anodizing
dust cover	aluminum alloy	white anodizing
sub table	aluminum alloy	white anodizing
top cover	aluminum alloy	

When LB option is selected, steel parts are treated with low temperature black chrome treatment.

BH30 –Without Top Cover–

A(1 long block)
B(2 long blocks)

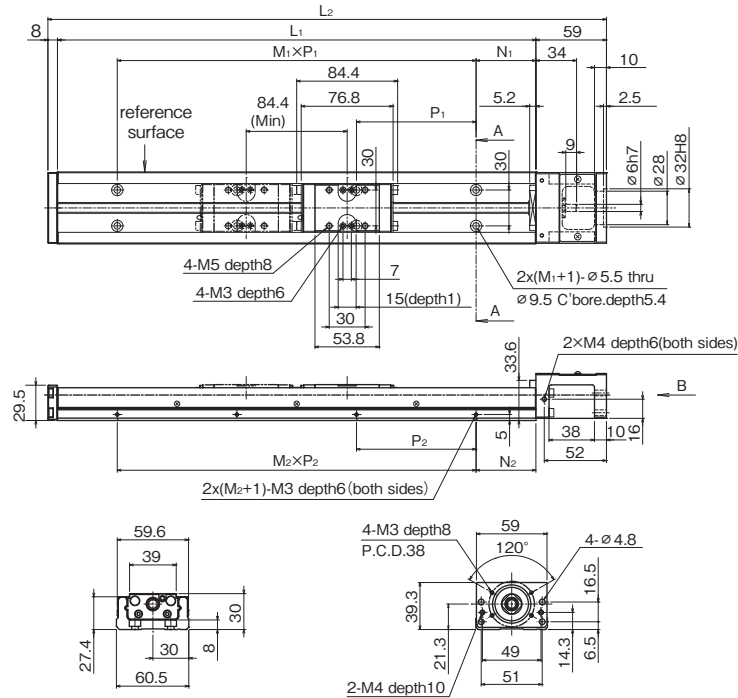

section A-A

View B (motor bracket A0)

refer to page G-104, 105 for other motor bracket

BH30 –With Top Cover–

A(1 long block)
B(2 long blocks)

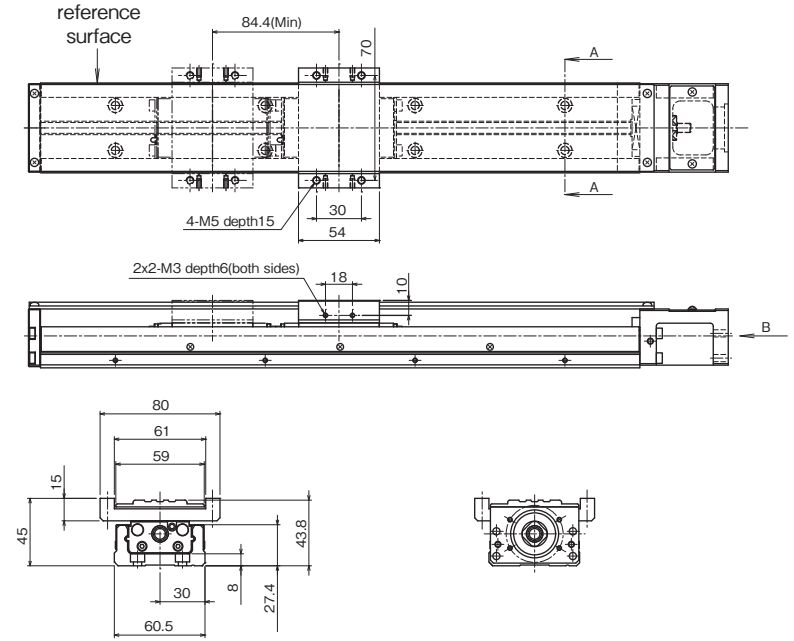

section A-A

View B (motor bracket A0)

refer to page G-104, 105 for other motor bracket

part number ^{3,4}	stroke limit mm ¹	dimensions mm						block mass kg ²		total mass kg			
		L ₁	L ₂	N ₁	M ₁ × P ₁	N ₂	M ₂ × P ₂	without top cover	with top cover	without top cover	with top cover		
BH30 □□ A-150	60	150	217	25	1 × 100	25	1 × 100	0.3	0.4	1.6	1.7		
B	—	—	—	—	—	—	—	—	—	—	—		
BH30 □□ A-200	110	200	267	50	1 × 100	50	1 × 100	0.3	0.4	1.9	2.1		
B	—	—	—	—	—	—	—	—	—	—	—		
BH30 □□ A-300	210	300	367	50	2 × 100	—	2 × 100	0.3	0.4	2.6	2.7		
B	126							0.6	0.8	2.9	3.2		
BH30 □□ A-400	310	400	467					3 × 100	3 × 100	0.3	0.4	3.3	3.4
B	226	0.6	0.8					3.6	3.8				
BH30 □□ A-500	410	500	567					4 × 100	4 × 100	0.3	0.4	3.9	4.1
B	326	0.6	0.8					4.2	4.5				
BH30 □□ A-600	510	600	667	5 × 100	5 × 100	0.3	0.4	4.6	4.7				
B	426	0.6	0.8	4.9	5.1								
BH30 □□ A-700	610	700	767	6 × 100	6 × 100	0.3	0.4	5.2	5.4				
B	526	0.6	0.8	5.5	5.8								
BH30 □□ A-750 ⁵	660	750	817	25	7 × 100	25	7 × 100	0.3	0.4	5.6	5.7		
B	576							0.6	0.8	5.9	6.1		

¹: Stroke limit is a drive distance between both ends of the dampers.

²: Mass stated "with top cover" includes mass of sub tables.

³: For B type (2 long blocks), drive block is located closest to motor bracket side.

⁴: □ is ballscrew lead.

⁵: For rail length 750mm, only lead 10mm is available.

inertia (reference values)

unit : kg · m²

part number	rail length mm	long block			
		without top cover		with top cover	
		A 1 block	B 2 blocks	A 1 block	B 2 blocks
BH3004	150	1.57 × 10 ⁻⁶	—	1.62 × 10 ⁻⁶	—
	200	1.96 × 10 ⁻⁶	—	2.01 × 10 ⁻⁶	—
	300	2.73 × 10 ⁻⁶	2.84 × 10 ⁻⁶	2.77 × 10 ⁻⁶	2.89 × 10 ⁻⁶
	400	3.50 × 10 ⁻⁶	3.61 × 10 ⁻⁶	3.54 × 10 ⁻⁶	3.66 × 10 ⁻⁶
	500	4.26 × 10 ⁻⁶	4.38 × 10 ⁻⁶	4.31 × 10 ⁻⁶	4.42 × 10 ⁻⁶
	600	5.03 × 10 ⁻⁶	5.14 × 10 ⁻⁶	5.07 × 10 ⁻⁶	5.19 × 10 ⁻⁶
BH3005	700	5.80 × 10 ⁻⁶	5.91 × 10 ⁻⁶	5.84 × 10 ⁻⁶	5.96 × 10 ⁻⁶
	150	1.65 × 10 ⁻⁶	—	1.72 × 10 ⁻⁶	—
	200	2.03 × 10 ⁻⁶	—	2.10 × 10 ⁻⁶	—
	300	2.80 × 10 ⁻⁶	2.98 × 10 ⁻⁶	2.87 × 10 ⁻⁶	3.05 × 10 ⁻⁶
	400	3.56 × 10 ⁻⁶	3.74 × 10 ⁻⁶	3.63 × 10 ⁻⁶	3.81 × 10 ⁻⁶
	500	4.33 × 10 ⁻⁶	4.51 × 10 ⁻⁶	4.40 × 10 ⁻⁶	4.58 × 10 ⁻⁶
BH3010	600	5.10 × 10 ⁻⁶	5.28 × 10 ⁻⁶	5.17 × 10 ⁻⁶	5.35 × 10 ⁻⁶
	700	5.87 × 10 ⁻⁶	6.05 × 10 ⁻⁶	5.93 × 10 ⁻⁶	6.11 × 10 ⁻⁶
	150	2.22 × 10 ⁻⁶	—	2.50 × 10 ⁻⁶	—
	200	2.61 × 10 ⁻⁶	—	2.88 × 10 ⁻⁶	—
	300	3.37 × 10 ⁻⁶	4.09 × 10 ⁻⁶	3.65 × 10 ⁻⁶	4.37 × 10 ⁻⁶
	400	4.14 × 10 ⁻⁶	4.86 × 10 ⁻⁶	4.42 × 10 ⁻⁶	5.14 × 10 ⁻⁶
BH3010	500	4.91 × 10 ⁻⁶	5.62 × 10 ⁻⁶	5.18 × 10 ⁻⁶	5.90 × 10 ⁻⁶
	600	5.67 × 10 ⁻⁶	6.39 × 10 ⁻⁶	5.95 × 10 ⁻⁶	6.67 × 10 ⁻⁶
	700	6.44 × 10 ⁻⁶	7.16 × 10 ⁻⁶	6.72 × 10 ⁻⁶	7.44 × 10 ⁻⁶
	750	6.82 × 10 ⁻⁶	7.54 × 10 ⁻⁶	7.10 × 10 ⁻⁶	7.82 × 10 ⁻⁶

part name	material	remarks
guide rail	carbon steel	black oxide except for raceway grooves
ballscrew shaft	carbon steel	
slide block	chromium-molybdenum steel	
motor bracket	aluminum alloy	black baked paint coating
coupling cover	aluminum alloy	black anodizing
housing	aluminum alloy	black anodizing
adapter plate	aluminum alloy	black anodizing
dust cover	aluminum alloy	white anodizing
sub table	aluminum alloy	white anodizing
top cover	aluminum alloy	

When LB option is selected, steel parts are treated with low temperature black chrome treatment.

BH45 –Without Top Cover–

A(1 long block)
B(2 long blocks)

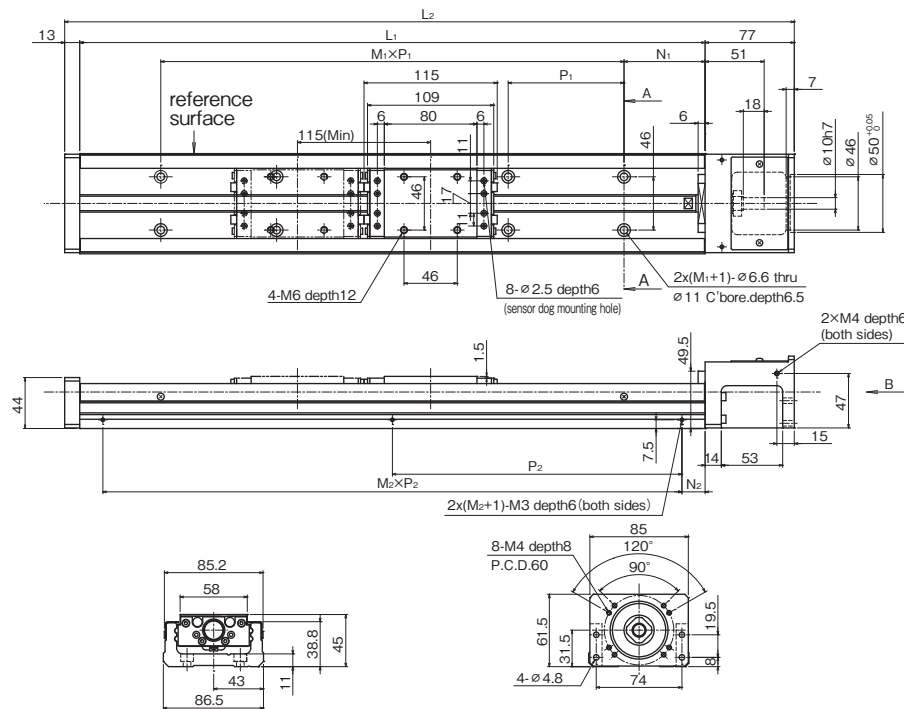

section A-A

View B (motor bracket A0)

refer to page G-106, 107 for other motor bracket

BH45 –With Top Cover–

A(1 long block)
B(2 long blocks)

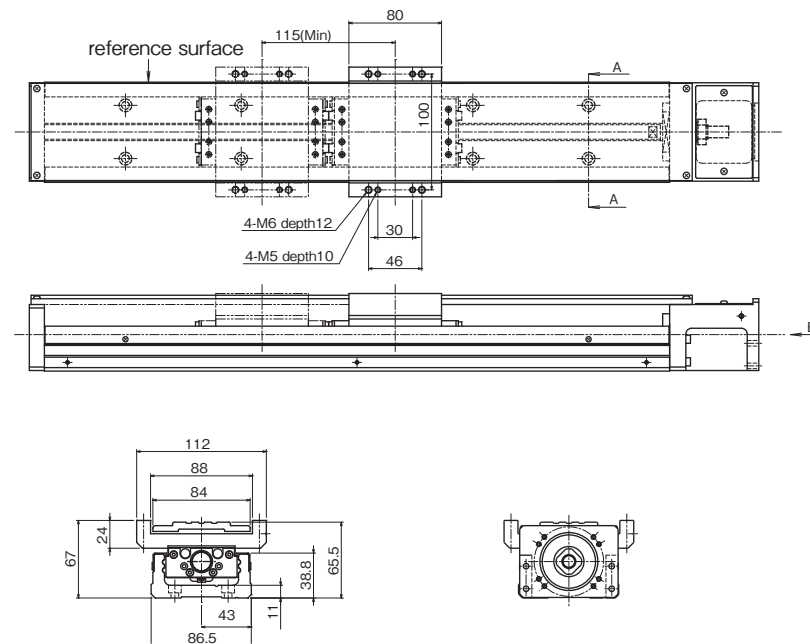

section A-A

View B (motor bracket A0)

refer to page G-106, 107 for other motor bracket

part number ^{3,4}	stroke limit mm ¹	dimensions mm				block mass kg ²		total mass kg				
		L ₁	L ₂	N ₁	M ₁ × P ₁	N ₂	M ₂ × P ₂	without top cover	with top cover			
BH45 □□ A-340	219	340	430	70	2 × 100	20	1 × 300	0.86	1.19	6	6.9	
B	104							1.72	2.38	6.9	8.1	
BH45 □□ A-440	319	440	530				3 × 100	1 × 400	0.86	1.19	7.3	8.3
B	204								1.72	2.38	8.2	9.5
BH45 □□ A-540	419	540	630				4 × 100	2 × 250	0.86	1.19	8.5	9.6
B	304								1.72	2.38	9.4	10.9
BH45 □□ A-640	519	640	730				5 × 100	2 × 300	0.86	1.19	9.8	11
B	404								1.72	2.38	10.7	12.2
BH45 □□ A-740	619	740	830	6 × 100	2 × 350	0.86	1.19	11	12.4			
B	504					1.72	2.38	11.9	13.6			
BH45 □□ A-840	719	840	930	7 × 100	2 × 400	0.86	1.19	12.3	13.8			
B	604					1.72	2.38	13.2	15			
BH45 □□ A-940	819	940	1,030	8 × 100	3 × 300	0.86	1.19	13.5	15.1			
B	704					1.72	2.38	14.4	16.4			

*1: Stroke limit is a drive distance between both ends of the dampers.

*2: Mass stated "with top cover" includes mass of sub tables.

*3: For B type (2 long blocks), drive block is located closest to motor bracket side.

*4: □ is ballscrew lead.

inertia (reference values)

unit : kg · m²

part number	rail length mm	long block			
		without top cover		with top cover	
		A 1 block	B 2 blocks	A 1 block	B 2 blocks
BH4505	340	1.63 × 10 ⁻⁵	1.68 × 10 ⁻⁵	1.65 × 10 ⁻⁵	1.72 × 10 ⁻⁵
	440	2.01 × 10 ⁻⁵	2.10 × 10 ⁻⁵	2.03 × 10 ⁻⁵	2.11 × 10 ⁻⁵
	540	2.40 × 10 ⁻⁵	2.46 × 10 ⁻⁵	2.42 × 10 ⁻⁵	2.50 × 10 ⁻⁵
	640	2.79 × 10 ⁻⁵	2.85 × 10 ⁻⁵	2.81 × 10 ⁻⁵	2.89 × 10 ⁻⁵
	740	3.17 × 10 ⁻⁵	3.24 × 10 ⁻⁵	3.20 × 10 ⁻⁵	3.28 × 10 ⁻⁵
BH4510	840	3.56 × 10 ⁻⁵	3.62 × 10 ⁻⁵	3.59 × 10 ⁻⁵	3.67 × 10 ⁻⁵
	940	3.95 × 10 ⁻⁵	4.01 × 10 ⁻⁵	3.98 × 10 ⁻⁵	4.05 × 10 ⁻⁵
	340	1.81 × 10 ⁻⁵	2.04 × 10 ⁻⁵	1.89 × 10 ⁻⁵	2.20 × 10 ⁻⁵
	440	2.20 × 10 ⁻⁵	2.42 × 10 ⁻⁵	2.28 × 10 ⁻⁵	2.59 × 10 ⁻⁵
	540	2.58 × 10 ⁻⁵	2.81 × 10 ⁻⁵	2.67 × 10 ⁻⁵	2.98 × 10 ⁻⁵
BH4520	640	2.97 × 10 ⁻⁵	3.20 × 10 ⁻⁵	3.06 × 10 ⁻⁵	3.37 × 10 ⁻⁵
	740	3.36 × 10 ⁻⁵	3.59 × 10 ⁻⁵	3.44 × 10 ⁻⁵	3.76 × 10 ⁻⁵
	840	3.75 × 10 ⁻⁵	3.98 × 10 ⁻⁵	3.83 × 10 ⁻⁵	4.14 × 10 ⁻⁵
	940	4.14 × 10 ⁻⁵	4.36 × 10 ⁻⁵	4.22 × 10 ⁻⁵	4.53 × 10 ⁻⁵
	340	2.54 × 10 ⁻⁵	3.45 × 10 ⁻⁵	2.87 × 10 ⁻⁵	4.12 × 10 ⁻⁵
BH4520	440	2.92 × 10 ⁻⁵	3.84 × 10 ⁻⁵	3.26 × 10 ⁻⁵	4.50 × 10 ⁻⁵
	540	3.31 × 10 ⁻⁵	4.22 × 10 ⁻⁵	3.65 × 10 ⁻⁵	4.89 × 10 ⁻⁵
	640	3.70 × 10 ⁻⁵	4.61 × 10 ⁻⁵	4.03 × 10 ⁻⁵	5.28 × 10 ⁻⁵
	740	4.09 × 10 ⁻⁵	5.00 × 10 ⁻⁵	4.42 × 10 ⁻⁵	5.67 × 10 ⁻⁵
	840	4.48 × 10 ⁻⁵	5.39 × 10 ⁻⁵	4.81 × 10 ⁻⁵	6.06 × 10 ⁻⁵
940	4.86 × 10 ⁻⁵	5.78 × 10 ⁻⁵	5.20 × 10 ⁻⁵	6.45 × 10 ⁻⁵	

part name	material	remarks
guide rail	carbon steel	black oxide except for raceway grooves
ballscrew shaft	carbon steel	
slide block	chromium-molybdenum steel	
motor bracket	aluminum alloy	black baked paint coating
coupling cover	aluminum alloy	black anodizing
housing	aluminum alloy	black anodizing
adapter plate	aluminum alloy	black anodizing
dust cover	aluminum alloy	white anodizing
sub table	aluminum alloy	white anodizing
top cover	aluminum alloy	

When LB option is selected, steel parts are treated with low temperature black chrome treatment.

BH45 –Without Top Cover–

C(1 short block)
D(2 short blocks)

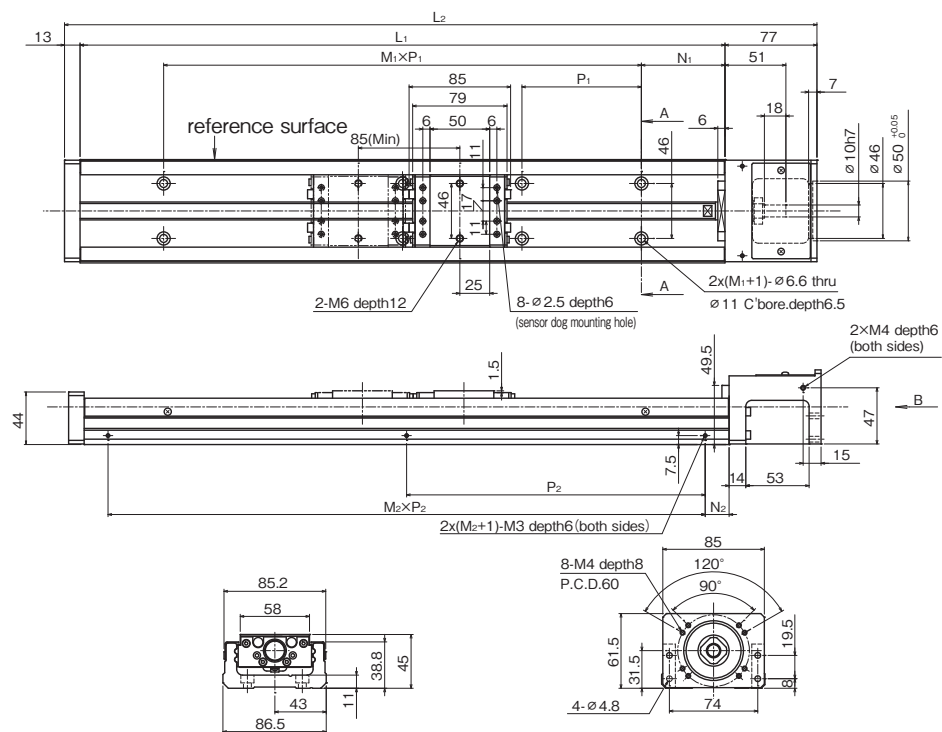

section A-A

View B (motor bracket A0)

refer to page G-106, 107 for other motor bracket

part number ^{3,4}	stroke limit mm ¹	dimensions mm		block mass kg ²		total mass kg					
		L ₁	L ₂	without top cover	with top cover	without top cover	with top cover				
BH45 □□ C-340	249	340	430	70	20	2 × 100	1 × 300	0.58	0.79	5.7	6.5
	D							164	1.16	1.58	6.3
BH45 □□ C-440	349	440	530			3 × 100	1 × 400	0.58	0.79	7	7.8
	D							264	1.16	1.58	7.6
BH45 □□ C-540	449	540	630			4 × 100	2 × 250	0.58	0.79	8.2	9.2
	D							364	1.16	1.58	8.8
BH45 □□ C-640	549	640	730			5 × 100	2 × 300	0.58	0.79	9.5	10.6
	D							464	1.16	1.58	10.1
BH45 □□ C-740	649	740	830	6 × 100	2 × 350	0.58	0.79	10.7	12		
	D					564	1.16	1.58	11.3	12.8	
BH45 □□ C-840	749	840	930	7 × 100	2 × 400	0.58	0.79	12	13.3		
	D					664	1.16	1.58	12.6	14.1	
BH45 □□ C-940	849	940	1,030	8 × 100	3 × 300	0.58	0.79	13.2	14.7		
	D					764	1.16	1.58	13.8	15.5	

*1: Stroke limit is a travel distance between both ends of the dampers.

*2: Mass stated "with top cover" includes mass of sub tables.

*3: For D type (2 short blocks), drive block is located closest to motor bracket side.

*4: □ is ballscrew lead.

BH45 –With Top Cover–

C(1 short block)
D(2 short blocks)

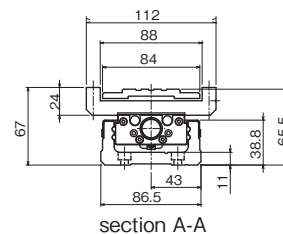
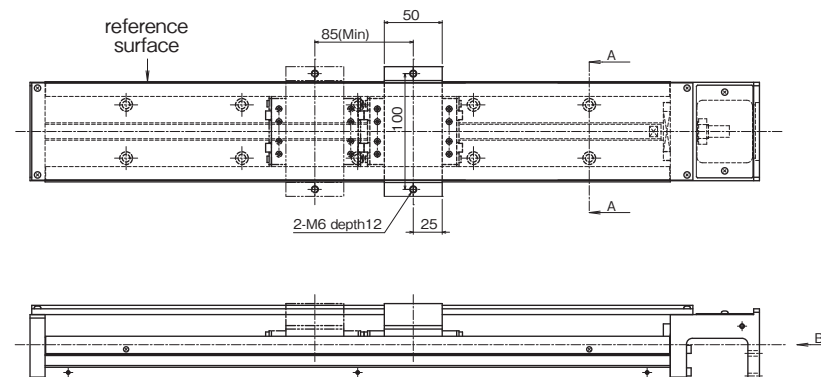

section A-A

View B (motor bracket A0)

refer to page G-106, 107 for other motor bracket

inertia (reference values)

unit : kg · m²

part number	rail length mm	short block			
		without top cover		with top cover	
		C	D	C	D
BH4505	340	1.61 × 10 ⁻⁵	1.64 × 10 ⁻⁵	1.62 × 10 ⁻⁵	1.67 × 10 ⁻⁵
	440	1.99 × 10 ⁻⁵	2.03 × 10 ⁻⁵	2.01 × 10 ⁻⁵	2.06 × 10 ⁻⁵
	540	2.38 × 10 ⁻⁵	2.42 × 10 ⁻⁵	2.40 × 10 ⁻⁵	2.45 × 10 ⁻⁵
	640	2.77 × 10 ⁻⁵	2.81 × 10 ⁻⁵	2.78 × 10 ⁻⁵	2.83 × 10 ⁻⁵
	740	3.16 × 10 ⁻⁵	3.20 × 10 ⁻⁵	3.17 × 10 ⁻⁵	3.22 × 10 ⁻⁵
BH4510	840	3.55 × 10 ⁻⁵	3.59 × 10 ⁻⁵	3.56 × 10 ⁻⁵	3.61 × 10 ⁻⁵
	940	3.94 × 10 ⁻⁵	3.97 × 10 ⁻⁵	3.95 × 10 ⁻⁵	4.00 × 10 ⁻⁵
	340	1.73 × 10 ⁻⁵	1.88 × 10 ⁻⁵	1.78 × 10 ⁻⁵	1.98 × 10 ⁻⁵
	440	2.12 × 10 ⁻⁵	2.27 × 10 ⁻⁵	2.17 × 10 ⁻⁵	2.37 × 10 ⁻⁵
	540	2.51 × 10 ⁻⁵	2.66 × 10 ⁻⁵	2.56 × 10 ⁻⁵	2.76 × 10 ⁻⁵
BH4520	640	2.90 × 10 ⁻⁵	3.05 × 10 ⁻⁵	2.95 × 10 ⁻⁵	3.15 × 10 ⁻⁵
	740	3.28 × 10 ⁻⁵	3.44 × 10 ⁻⁵	3.33 × 10 ⁻⁵	3.54 × 10 ⁻⁵
	840	3.67 × 10 ⁻⁵	3.82 × 10 ⁻⁵	3.72 × 10 ⁻⁵	3.93 × 10 ⁻⁵
	940	4.06 × 10 ⁻⁵	4.21 × 10 ⁻⁵	4.11 × 10 ⁻⁵	4.31 × 10 ⁻⁵
	340	2.23 × 10 ⁻⁵	2.84 × 10 ⁻⁵	2.43 × 10 ⁻⁵	3.24 × 10 ⁻⁵
BH4520	440	2.62 × 10 ⁻⁵	3.23 × 10 ⁻⁵	2.82 × 10 ⁻⁵	3.63 × 10 ⁻⁵
	540	3.01 × 10 ⁻⁵	3.62 × 10 ⁻⁵	3.21 × 10 ⁻⁵	4.02 × 10 ⁻⁵
	640	3.40 × 10 ⁻⁵	4.00 × 10 ⁻⁵	3.60 × 10 ⁻⁵	4.41 × 10 ⁻⁵
	740	3.78 × 10 ⁻⁵	4.39 × 10 ⁻⁵	3.99 × 10 ⁻⁵	4.80 × 10 ⁻⁵
	840	4.17 × 10 ⁻⁵	4.78 × 10 ⁻⁵	4.38 × 10 ⁻⁵	5.19 × 10 ⁻⁵
940	4.56 × 10 ⁻⁵	5.17 × 10 ⁻⁵	4.76 × 10 ⁻⁵	5.57 × 10 ⁻⁵	

part name	material	remarks
guide rail	carbon steel	black oxide except for raceway grooves
ballscrew shaft	carbon steel	
slide block	chromium-molybdenum steel	
motor bracket	aluminum alloy	black baked paint coating
coupling cover	aluminum alloy	black anodizing
housing	aluminum alloy	black anodizing
adapter plate	aluminum alloy	black anodizing
dust cover	aluminum alloy	white anodizing
sub table	aluminum alloy	white anodizing
top cover	aluminum alloy	

When LB option is selected, steel parts are treated with low temperature black chrome treatment.

MOTOR BRACKET CONFIGURATIONS & APPLICABLE MOTORS

NB provides optional motor brackets and adapter plates to easily install most popular motors.

Table G-24 (1) Applicable Motors

Applicable motors		Output	BH15	BH23	BH30	BH45		
			P.G-102	P.G-103	P.G-104 ~ 105	P.G-106 ~ 107		
AC Servo motor	Panasonic	A5	MSME5A	50W	—	A3	A2	A5
			MSME01	100W	—	—	—	—
			MSME02	200W	—	—	—	—
			MSME04	400W	—	—	—	—
		MSME08	750W	—	—	—	—	
		A6	MSMF5A	50W	—	A3	A2	A5
			MSMF01	100W	—	—	—	—
			MSMF02	200W	—	—	—	—
	MSMF04		400W	—	—	—	—	
	MSMF08	750W	—	—	—	—		
	MITSUBISHI ELECTRIC	J3	HF-KP(MP)053	50W	—	A1	A1	A4
			HF-KP(MP)13	100W	—	—	—	—
			HF-KP(MP)23	200W	—	—	A7	A1
			HF-KP(MP)43	400W	—	—	—	—
			HF-KP(MP)73	750W	—	—	—	—
		J4	HG-AK0136	10W	A1	—	—	—
HG-AK0236			20W	—	—	—	—	
HG-AK0336			30W	—	—	—	—	
HG-KR(MR)053			50W	—	A1	A1	A4	
HG-KR(MR)13			100W	—	—	—	—	
HG-KR(MR)23			200W	—	—	A7	A1	
HG-KR(MR)43			400W	—	—	—	—	
HG-KR(MR)73			750W	—	—	—	—	
YASKAWA ELECTRIC		Σ - V mini	SGMMV-A1	10W	A1	—	—	
			SGMMV-A2	20W	—	—	—	
			SGMMV-A3	30W	—	—	—	
	Σ - V	SGMJV(SGMAV)-A5	50W	—	A1	A1	A4	
		SGMJV(SGMAV)-01	100W	—	—	—	—	
		SGMAV-C2	150W	—	—	—	—	
		SGMJV(SGMAV)-02	200W	—	—	A7	A1	
		SGMJV(SGMAV)-04	400W	—	—	—	—	
		SGMAV-06	550W	—	—	—	—	
		SGMJV(SGMAV)-08	750W	—	—	—	—	
		SGM7J(SGM7A)-A5	50W	—	A1	A1	A4	
	Σ - 7	SGM7J(SGM7A)-01	100W	—	—	—	—	
		SGM7J(SGM7A)-C2	150W	—	—	—	—	
		SGM7J(SGM7A)-02	200W	—	—	A7	A1	
		SGM7J(SGM7A)-04	400W	—	—	—	—	
		SGM7J(SGM7A)-06	600W	—	—	—	—	
SGM7J(SGM7A)-08	750W	—	—	—	—			

Table G-24 (2) Applicable Motors

Applicable motors		Output	BH15	BH23	BH30	BH45		
			P.G-102	P.G-103	P.G-104 ~ 105	P.G-106 ~ 107		
AC Servo motor	SANYO DENKI	Q	Q1AA04003D	30W	—	A1	A1	A4
			Q1AA04005D	50W	—	—	—	—
			Q1AA04010D	100W	—	—	—	—
			Q1AA06020D	200W	—	—	A7	A1
			Q1AA06040D	400W	—	—	—	—
			Q1AA07075D	750W	—	—	—	—
		R	R2AA04005	50W	—	A1	A1	A4
			R2AA04010	100W	—	—	—	—
			R2AA06020	200W	—	—	A7	A1
			R2AA06040	400W	—	—	—	—
	R2AA08075	750W	—	—	—	—		
	OMRON	G	R88M-G05030	50W	—	A1	A1	A4
			R88M-G10030	100W	—	—	—	—
			R88M-G20030	200W	—	—	—	A2
			R88M-G40030	400W	—	—	—	—
			R88M-G75030	750W	—	—	—	—
		G5	R88M-K05030	50W	—	A1	A1	A4
			R88M-K10030	100W	—	—	—	—
			R88M-K20030	200W	—	—	—	A2
			R88M-K40030	400W	—	—	—	—
			R88M-K75030	750W	—	—	—	—
	1S	R88M-1M10030	100W	—	A1	A1	A4	
		R88M-1M20030	200W	—	—	—	A2	
		R88M-1M75030	750W	—	—	—	—	
	KEYENCE	MV	MV-M005	50W	—	A1	A1	A4
			MV-M010	100W	—	—	—	—
			MV-M020	200W	—	—	A7	A1
			MV-M040	400W	—	—	—	—
			MV-M075	750W	—	—	—	—
		SV	SV(SV2)-M005	50W	—	A1	A1	A4
			SV(SV2)-M010	100W	—	—	—	—
			SV(SV2)-M020	200W	—	—	A7	A1
			SV(SV2)-M040	400W	—	—	—	—
			SV(SV2)-M075	750W	—	—	—	—
	FANUC	β is	β is0.2/5000	50W	—	A1	A1	A4
			β is0.3/5000	100W	—	—	—	—
β is0.4/5000 ※			130W	—	—	A7	A1	
β is0.5/6000 ※			350W	—	—	—	—	
β is1/6000			500W	—	—	—	—	

※Please contact NB for the coupling because the motor shaft length will be shortened. NB can provide other types of motor brackets. Please contact NB for details.

MOTOR BRACKET CONFIGURATIONS & APPLICABLE MOTORS

Table G-25 (1) Applicable Motors

Applicable motors				Flange	BH15	BH23	BH30	BH45			
					P.G-102	P.G-103	P.G-104 ~ 105	P.G-106 ~ 107			
Stepper motor	ORIENTAL MOTOR	α step	AR	AR2	□ 28	A3	A6	—	—		
				AR46	□ 42	—	A5	B1	—		
				AR6	□ 60	—	—	A4	A6		
			AZ	AZM2	□ 28	A3	A6	—	—		
				AZM4	□ 42	—	A5	B1	—		
				AZM6	□ 60	—	—	A4	A6		
		5 phase motor	RK II	RKS54	□ 42	—	A5	B1	—		
				RKS56	□ 60	—	—	A4	A6		
				CRK52	□ 28	A3	A6	—	—		
			CRK	CRK54	□ 42	—	A5	B1	—		
				CRK56	□ 60	—	—	A4	A6		
				CVK (PKP)	PKP52	□ 28	A3	A6	—	—	
	PKP54	□ 42	—		A5	B1	—				
	PKP56	□ 56.4	—		—	A5	—				
	2 phase motor	CVK (PKP)	PKP56 □ F	□ 60	—	—	A4	A6			
			PKP22	□ 28	A3	A6	—	—			
			PKP24	□ 42	—	A5	B1	—			
			PKP26	□ 56.4	—	—	A5	—			
			SANYO DENKI	5 phase motor	F5	SH528	□ 28	A3	A6	—	—
						SM542	□ 42	—	A5	B1	—
	SM560	□ 60				—	—	A4	A6		
	2 phase motor	F2		SH228	□ 28	A3	A6	—	—		
				SH142,103H52	□ 42	—	A5	B1	—		
				103H712	□ 56.4	—	—	A5	—		
TECHNO DRIVE	5 phase motor		103H782 (connector type)	□ 60	—	—	A4	A6			
			□ K-S54 □	□ 42	—	A5	B1	—			
			□ K-S(M)56 □	□ 60	—	—	A4	A6			

NB can provide other types of motor brackets. Please contact NB for details.

Table G-25 (2) Applicable Motors

Applicable motors				Flange	BH15	BH23	BH30	BH45
					P.G-102	P.G-103	P.G-104 ~ 105	P.G-106 ~ 107
Stepper motor	TAMAGAWA SEIKI	2 phase motor	TS3641	□ 28	A3	A6	—	—
			TS3617	□ 42	—	A5	B1	—
			TS3690	□ 56.4	—	—	A5	—
		5 phase motor	TS3667	□ 42	—	A5	B1	—
			TS3624 *	□ 60	—	—	A4	A6
			i-STEP	TS3699N112	□ 28	A3	A6	—
	TS3699N172	□ 42		—	A5	B1	—	
	TS3699N231(N232)	□ 56.4		—	—	A5	—	
	sammei electronics	Si servo	TS3641	□ 28	A3	A6	—	—
			TS3617	□ 42	—	A5	B1	—
			TS3653	□ 56.4	—	—	A5	—
		Si super	SM-L5MH	□ 28	A3	A6	—	—
SM-02MH/SM-04MH			□ 42	—	A5	B1	—	
SM-09MH/SM-12MH			□ 56.4	—	—	A5	—	

※Please contact NB for the coupling because the motor shaft length will be shortened.

BH15

Figures inside() indicates mass of the motor mount adapter plate.

A0

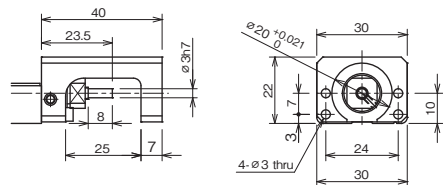

A1 (Mass:10g)

Recommended Coupling:
 XBW-15C2(Nabeya Bi-tech Kaisha)
 LAD-15C(Sakai Manufacturing Co., Ltd.)
 SFC-005DA2(Miki Pulley Co., Ltd.)

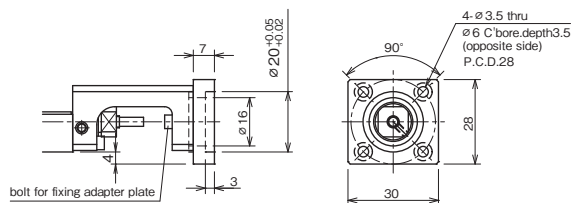

A2 (Mass:10g)

Recommended Coupling:
 XBW-15C2(Nabeya Bi-tech Kaisha)
 SFC-005DA2(Miki Pulley Co., Ltd.)

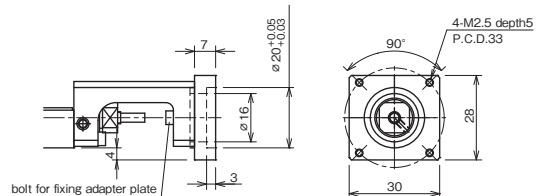

A3 (Mass:10g)

Recommended Coupling:
 XBW-15C2(Nabeya Bi-tech Kaisha)
 LAD-15C(Sakai Manufacturing Co., Ltd.)
 SFC-005DA2(Miki Pulley Co., Ltd.)

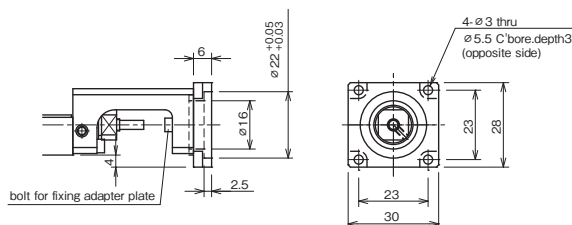

For configurations A1 and A3, attach the motor to the motor mount adapter plate first before mounting it to actuator.

BH23

Figures inside() indicates mass of the motor mount adapter plate.

A0

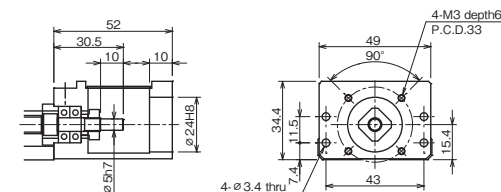

A1 (Mass:28g)

Recommended Coupling:
 XBW-19C2(Nabeya Bi-tech Kaisha)
 LAD-20C(Sakai Manufacturing Co., Ltd.)
 SFC-010DA2(Miki Pulley Co., Ltd.)

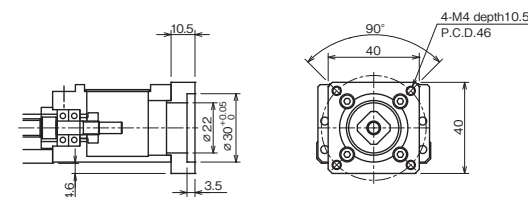

A3 (Mass:24g)

Recommended Coupling:
 XBW-19C2(Nabeya Bi-tech Kaisha)
 LAD-20C(Sakai Manufacturing Co., Ltd.)
 SFC-010DA2(Miki Pulley Co., Ltd.)

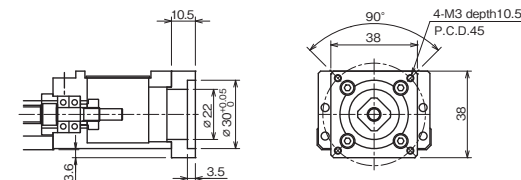

A5 (Mass:32g)

Recommended Coupling:
 XBW-19C2(Nabeya Bi-tech Kaisha)
 LAD-20C(Sakai Manufacturing Co., Ltd.)
 SFC-010DA2(Miki Pulley Co., Ltd.)

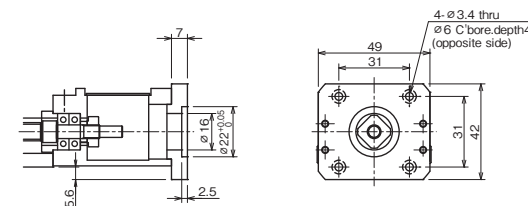

A6 (Mass:16g)

Recommended Coupling:
 XBW-19C2(Nabeya Bi-tech Kaisha)
 LAD-20C(Sakai Manufacturing Co., Ltd.)
 SFC-010DA2(Miki Pulley Co., Ltd.)

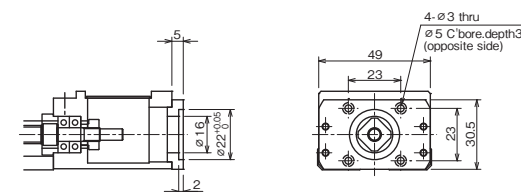

For configurations A5 and A6, attach the motor to the motor mount adapter plate first before mounting it to actuator.

BH30

Figures inside() indicates mass of the motor mount adapter plate.

A0

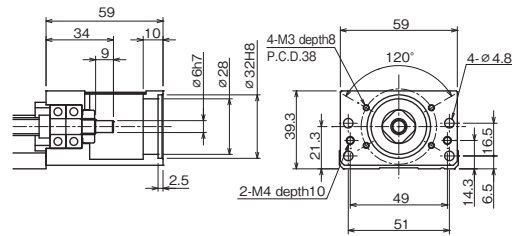

A1 (Mass:25g)

Recommended Coupling:
 XBW-25C2(Nabeya Bi-tech Kaisha)
 LAD-25C(Sakai Manufacturing Co., Ltd.)
 SFC-020DA2(Miki Pulley Co., Ltd.)

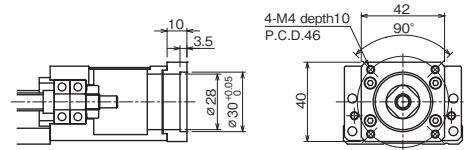

A2 (Mass:25g)

Recommended Coupling:
 XBW-25C2(Nabeya Bi-tech Kaisha)
 LAD-25C(Sakai Manufacturing Co., Ltd.)
 SFC-020DA2(Miki Pulley Co., Ltd.)

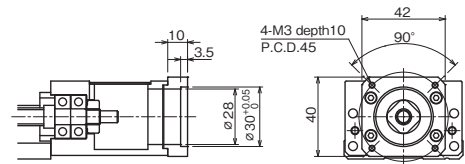

A3 (Mass:55g)

Recommended Coupling:
 XBW-25C2(Nabeya Bi-tech Kaisha)
 LAD-25C(Sakai Manufacturing Co., Ltd.)
 SFC-020DA2(Miki Pulley Co., Ltd.)

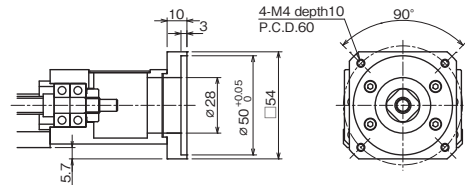

A4 (Mass:71 g)

Recommended Coupling:
 XBW-25C2(Nabeya Bi-tech Kaisha)
 LAD-25C(Sakai Manufacturing Co., Ltd.)
 SFC-020DA2(Miki Pulley Co., Ltd.)

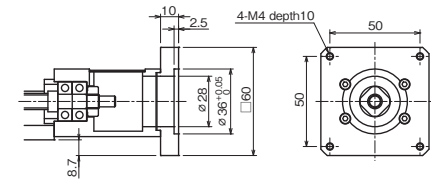

A5 (Mass:46g)

Recommended Coupling:
 XBW-25C2(Nabeya Bi-tech Kaisha)
 LAD-25C(Sakai Manufacturing Co., Ltd.)
 SFC-020DA2(Miki Pulley Co., Ltd.)

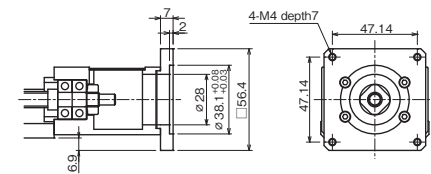

A7 (Mass:64g)

Recommended Coupling:
 XBW-27C2(Nabeya Bi-tech Kaisha)

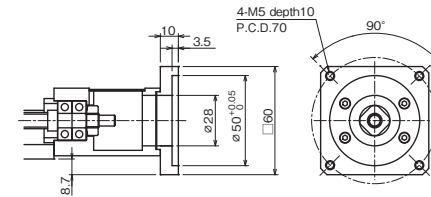

B1 (Mass:37g)

Recommended Coupling:
 XBW-19C2(Nabeya Bi-tech Kaisha)
 LAD-20C(Sakai Manufacturing Co., Ltd.)
 SFC-010DA2(Miki Pulley Co., Ltd.)

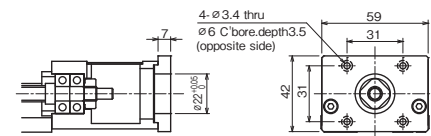

For configuration B1, attach the motor to the motor mount adapter plate first before mounting it to actuator.

BH45

Figures inside () indicates mass of the motor mount adapter plate.

A0

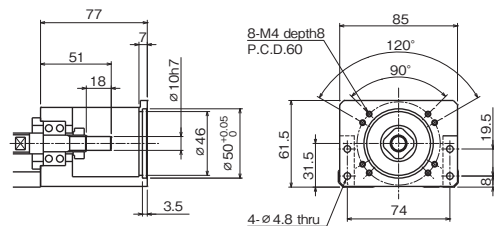

A1 (Mass:53g)

Recommended Coupling:
 XBW-34C3(Nabeya Bi-tech Kaisha)
 LAD-30C (Sakai Manufacturing Co., Ltd.)
 SFC-030DA2 (Miki Pulley Co., Ltd.)

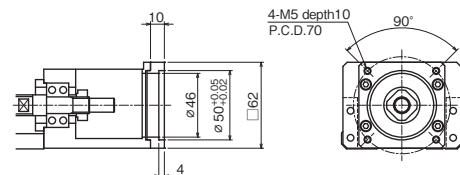

A2 (Mass:53g)

Recommended Coupling:
 XBW-34C3(Nabeya Bi-tech Kaisha)
 LAD-30C (Sakai Manufacturing Co., Ltd.)
 SFC-030DA2 (Miki Pulley Co., Ltd.)

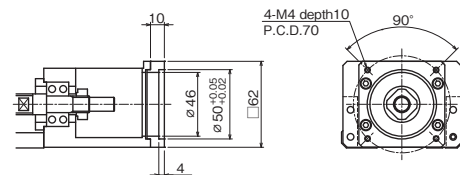

A3 (Mass:103g)

(200W-400W)
 Recommended Coupling:
 XBW-34C3(Nabeya Bi-tech Kaisha)
 SFC-030DA2 (Miki Pulley Co., Ltd.)
 (750W)
 Recommended Coupling:
 XBW-39C2 (Nabeya Bi-tech Kaisha)
 SFC-040DA2 (Miki Pulley Co., Ltd.)

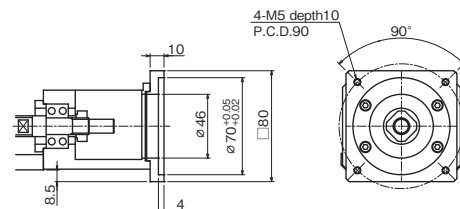

A4 (Mass:73g)

Recommended Coupling:
 XBW-25C2(Nabeya Bi-tech Kaisha)
 LAD-25C (Sakai Manufacturing Co., Ltd.)
 SFC-020DA2 (Miki Pulley Co., Ltd.)

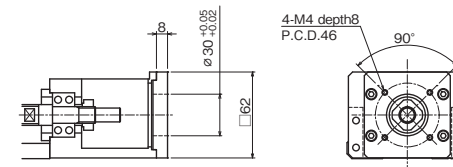

A5 (Mass:73g)

Recommended Coupling:
 XBW-25C2(Nabeya Bi-tech Kaisha)
 LAD-25C (Sakai Manufacturing Co., Ltd.)
 SFC-020DA2 (Miki Pulley Co., Ltd.)

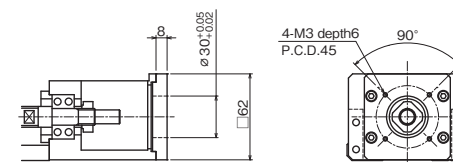

A6 (Mass:64g)

Recommended Coupling:
 XBW-27C2(Nabeya Bi-tech Kaisha)
 LAD-25C (Sakai Manufacturing Co., Ltd.)*
 SFC-020DA2 (Miki Pulley Co., Ltd.)*
 *Please contact NB if you are using aSTEP motor (Oriental Motor Co., Ltd.)

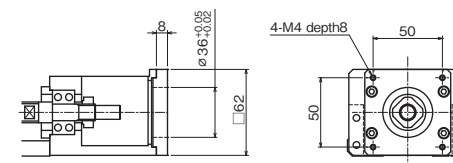

EXPOSED BRACKET R0

The BH type ballscrew shaft end is exposed with the exposed bracket R0 type. Please fabricate an original bracket in case the standard brackets are not applicable. R0 type is applicable with cover and with sensors.

BH30

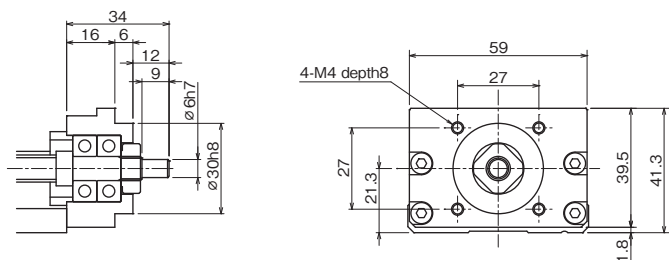

Mass is 0.085kg less than the mass in the table on page G-92.

BH45

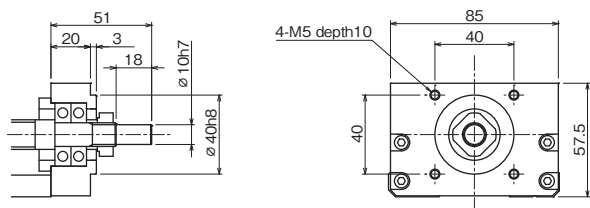

Mass is 0.26kg less than the mass in the table on page G-94 and G-96.

RETURN PULLEY UNIT

Return pulley units in which a motor is connected with a timing belt are available for BH type. Its return structure allows the reduction of total length (available for BH30 and BH45).

BH30

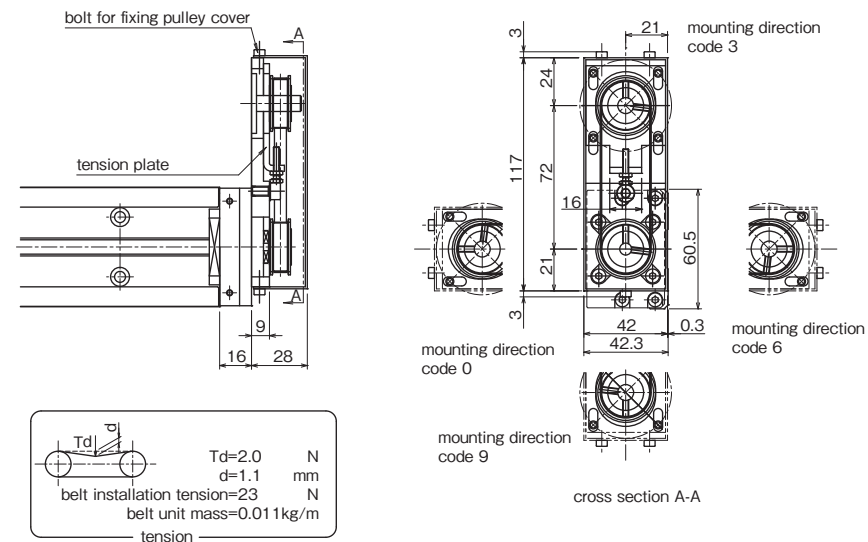

1. Installation position of Pulley Unit can be selected at 90° intervals (mounting direction code).
2. Applicable with cover and with sensors.
3. 0.2kg is added to the mass on page G-92.
4. Inertia is added 2.22x10⁻⁶kg · m² to the value on page G-93.
5. Part number structure BH30***-****/☆☆□
 ☆☆: Symbol of applicable motor bracket (refer to Table G-26)
 □: Mounting direction code (refer to cross section A-A)

Table G-26 Applicable Motor Bracket

motor bracket	applicable motors		rated output	flange	motor shaft dia.
RA	Panasonic	MINAS SERIES	50 ~ 100 W	□ 38	φ 8
RB	YASKAWA ELECTRIC	SIGMA SERIES	50 ~ 100 W	□ 40	φ 8
	MITSUBISHI ELECTRIC	MELSERVO SERIES	50 ~ 100 W	□ 40	
	SANYO DENKI	SANMOTION Q1 SERIES	50 ~ 100 W	□ 40	

BH45

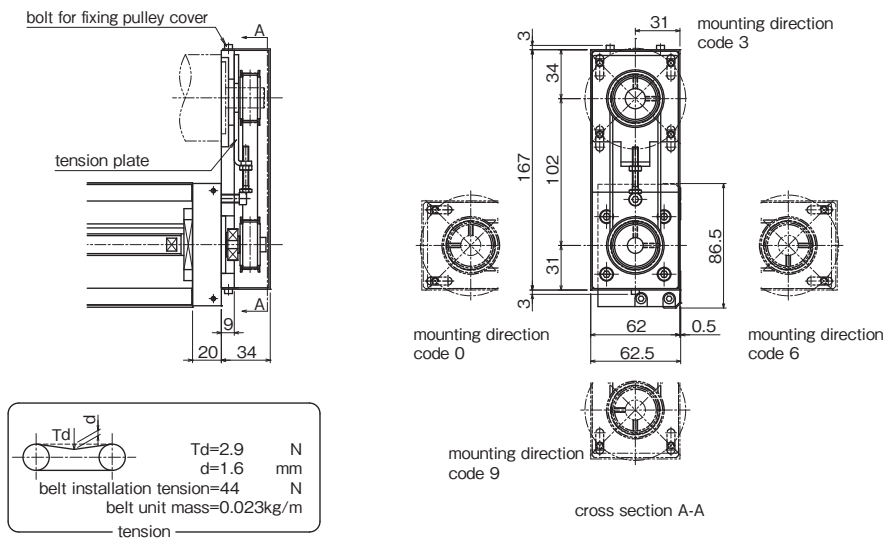

1. Installation position of Pulley Unit can be selected at 90° intervals (mounting direction code).
2. Applicable with cover and with sensors.
3. 0.7kg is added to the mass on page G-94 and G-96.
4. Inertia is added $1.24 \times 10^{-5} \text{kg} \cdot \text{m}^2$ to the value on page G-95 and G-97.
5. Part number structure BH45*****/☆☆□
 ☆☆☆: Symbol of applicable motor bracket (refer to Table G-27)
 □: Mounting direction code (refer to cross section A-A)

Table G-27 Applicable Motor Bracket

motor bracket	applicable motors		rated output	flange	motor shaft dia.
RA	Panasonic	MINAS SERIES	200 W	□ 60	φ 11
RB	YASKAWA ELECTRIC	SIGMA SERIES	200 W	□ 60	φ 14
	MITSUBISHI ELECTRIC	MELSERVO SERIES	200 W	□ 60	
	SANYO DENKI	SANMOTION Q1 SERIES	200 W	□ 60	
RC	5 PHASE STEPPING MOTOR		—	□ 60	φ 8

SENSOR

Photomicro sensor or proximity sensor can be attached to the BH actuator with our optional sensor-mounting rail (refer to Table G-28). Tapped holes are machined on both sides of the guide rail, allowing attachment of sensor rail to either side. The case without special instruction from customer, standard positioning would be to the left of the motor mount end. When with two blocks, sensor dog is attached on the driving block as standard. Please change to attach sensor dog on the driven block if necessary.

Table G-28 Standard (NPN) Sensor

sensor symbol	sensor type	BH15	BH23	BH30	BH45
S	slim/compact type photomicro sensor	—	PM-L25 [3 pcs] *1 (SUNX)	EE-SX674 [3 pcs] *2 (OMRON)	
K	proximity sensor (N.C. contact) *3		APM-D3B1 [2 pcs]*1 APM-D3B1F [1 pc]*1*4 (Azbil)		

- *1: length of cable: 1m
- *2: 3 pcs of connector EE-1001 (OMRON) will be attached
- *3: normal close contact
- *4: different frequency type

Figure G-25 Sensor Rail

BH15

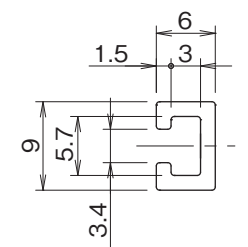

BH23, 30, 45

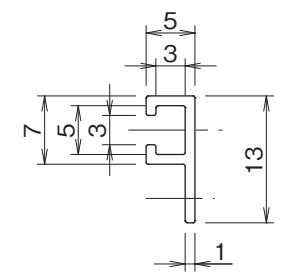

BH15

K Specification (Proximity Sensor)

—Without Top Cover—

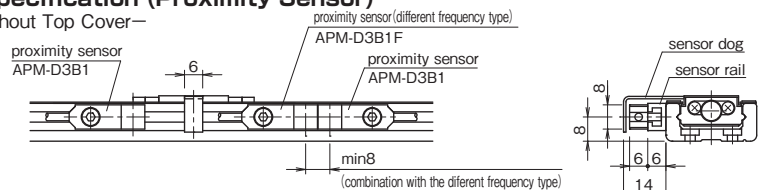

—With Top Cover—

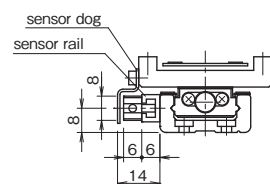
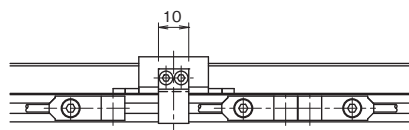

accessories

part name	qty
proximity sensor: APM-D3B1 (Azbil)	2 pcs
proximity sensor (different frequency type): APM-D3B1F (Azbil)	1 pc
sensor rail	1 pc
sensor dog	1 pc

BH23

S Specification (Compact Photomicro Sensor)

—Without Top Cover—

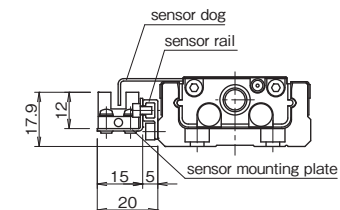
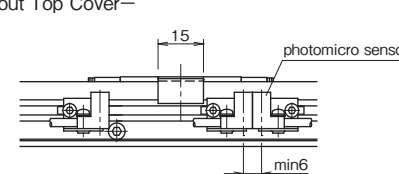

—With Top Cover—

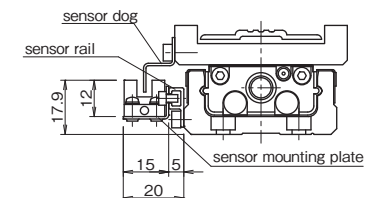
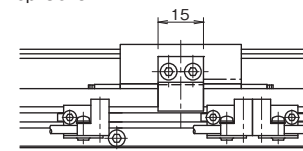

accessories

part name	qty
photomicro sensor: PM-L25 (SUNX)	3 pcs
sensor mounting plate	3 pcs
sensor rail	1 pc
sensor dog	1 pc

K Specification (Proximity Sensor)

—Without Top Cover—

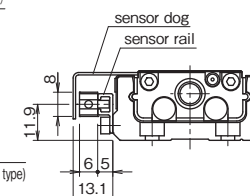
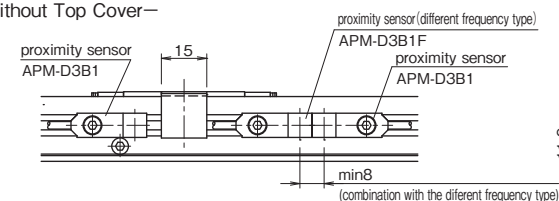

—With Top Cover—

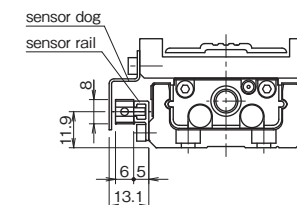
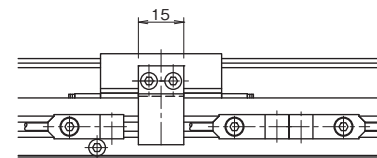

accessories

part name	qty
proximity sensor: APM-D3B1 (Azbil)	2 pcs
proximity sensor (different frequency type): APM-D3B1F (Azbil)	1 pc
sensor rail	1 pc
sensor dog	1 pc

BH30

S Specification (Slim-Type Photomicro Sensor)

—Without Top Cover—

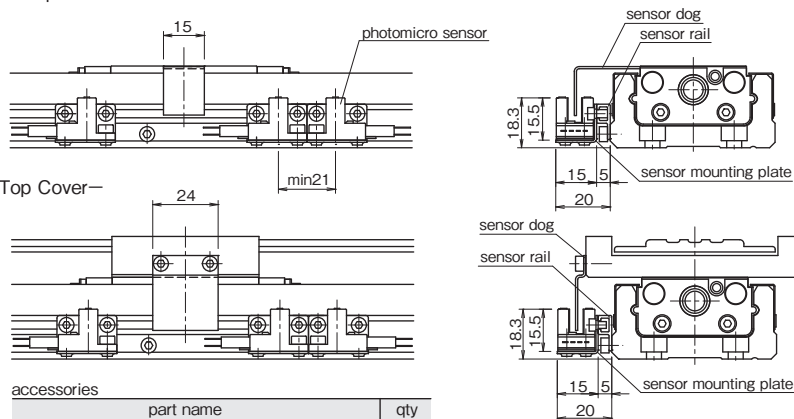

—With Top Cover—

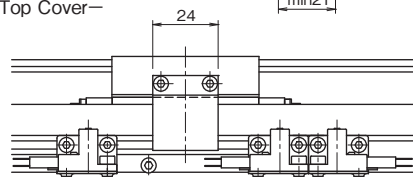

accessories		
part name		qty
photomicro sensor: EE-SX674 (OMRON)		3 pcs
connector: EE-1001 (OMRON)		3 pcs
sensor mounting plate		3 pcs
sensor rail		1 pc
sensor dog		1 pc

K Specification (Proximity Sensor)

—Without Top Cover—

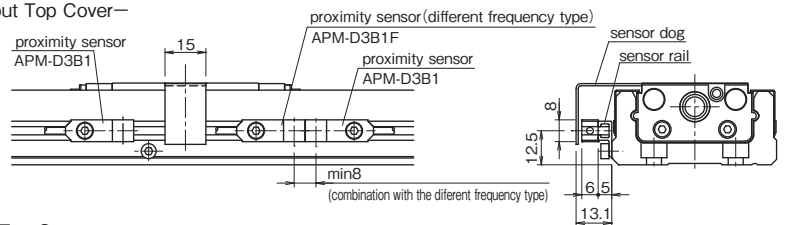

—With Top Cover—

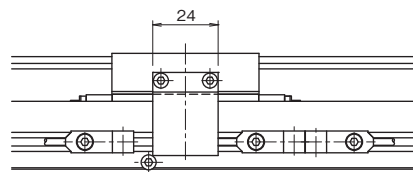

accessories		
part name		qty
proximity sensor: APM-D3B1 (Azbil)		2 pcs
proximity sensor (different frequency type): APM-D3B1F (Azbil)		1 pc
sensor rail		1 pc
sensor dog		1 pc

BH45

S Specification (Slim-Type Photomicro Sensor)

—Without Top Cover—

long block

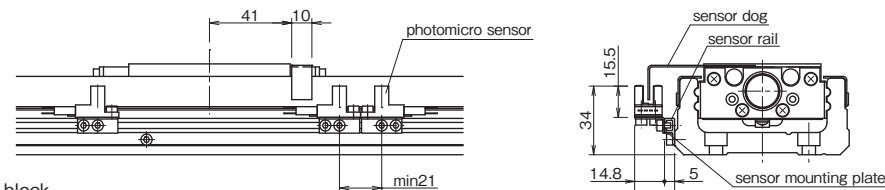

short block

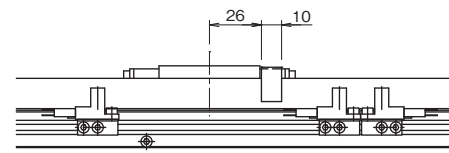

—With Top Cover—

long block

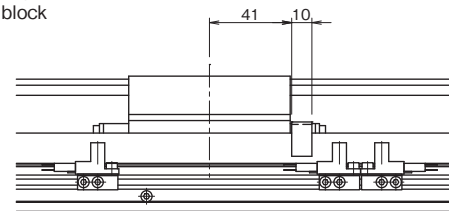

short block

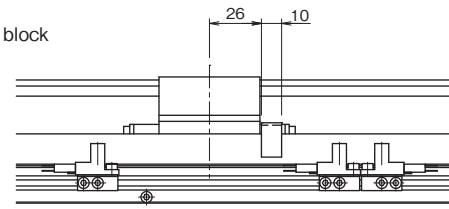

accessories		
part name		qty
photomicro sensor: EE-SX674 (OMRON)		3 pcs
connector: EE-1001 (OMRON)		3 pcs
sensor mounting plate		3 pcs
sensor rail		1 pc
sensor dog		1 pc

BH45

K Specification (Proximity Sensor)

—Without Top Cover—
long block

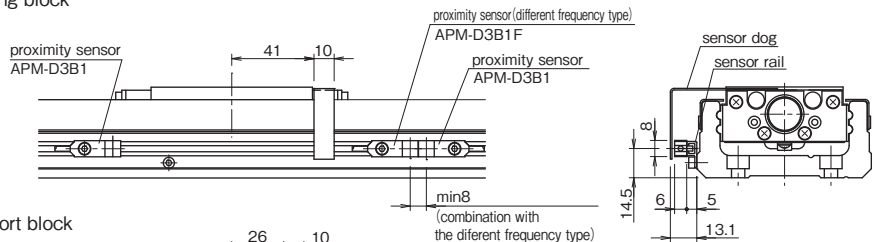

short block

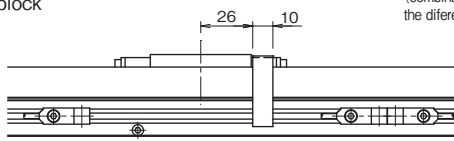

—With Top Cover—
long block

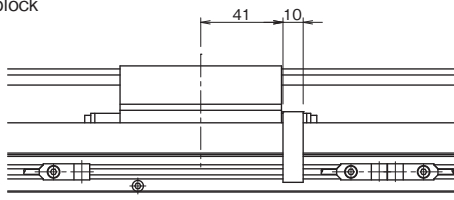

short block

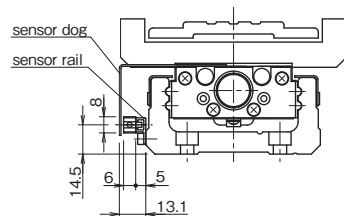
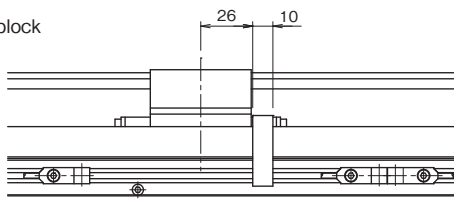

PNP SENSOR

For the BH type sensors can be changed to the PNP type by adding a sensor option code “PNP” at the end of the part number. Refer to Table G-29 for the model number of PNP type sensors.

Table G-29 Standard (PNP) Sensor

sensor symbol	sensor type	BH15	BH23	BH30	BH45
S	slim/compact type photomicro sensor	—	PM-L25-P [3 pcs] ^{*1} (SUNX)	EE-SX674P [3 pcs] ^{*2} (OMRON)	
K	proximity sensor (N.C. contact) ^{*3}	APM-D3E1 [2 pcs] ^{*1} APM-D3E1F [1 pc] ^{*1*4} (Azbil)			

- *1: length of cable: 1m
- *2: 3 pcs of connector EE-1001 (OMRON) will be attached
- *3: normal close contact
- *4: different frequency type

accessories

part name	qty
proximity sensor: APM-D3B1 (Azbil)	2 pcs
proximity sensor (different frequency type): APM-D3B1F (Azbil)	1 pc
sensor rail	1 pc
sensor dog	1 pc

POSITIONING PIN HOLE

For the BH type, positioning pin holes can be provided on the slide block and sub table by adding the option code "PS" or "PW" in the end of the part number.

The option code "PR" is used to provide the guide rail with positioning pin holes. When positioning pin holes are necessary on both the slide block/sub table and guide rail, please add the option code "PSR" or "PWR"

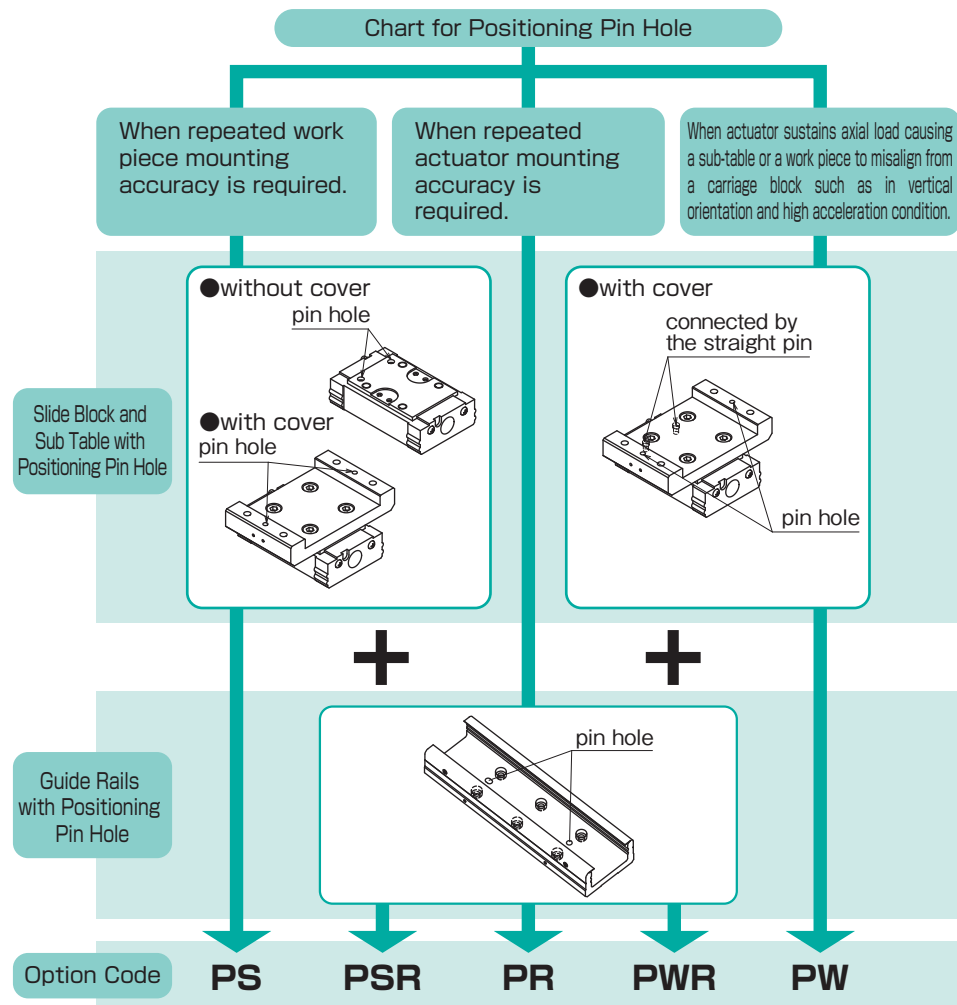

Positioning Pin Hole for Slide Block and Sub Table

It is useful when exacting reassembly positioning is required. In case of two blocks used, both blocks are processed.

When the code "PS" is specified, the drilling hole is processed only on the mounting surface (slide block or sub table). When the code "PW" is specified for a BH with a top cover, the slide block and sub table are connected by the straight pins at the location where the "PS" option specifies on the slide block.

Note that NB does not supply straight pins for the "PS" option.

BH15A,B (long block)

Positioning pin hole option is not available for BH15.

BH23A,B (long block)

- PS Option Without Top Cover -

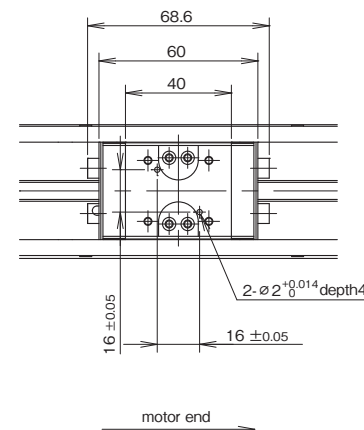

- PS Option With Top Cover -

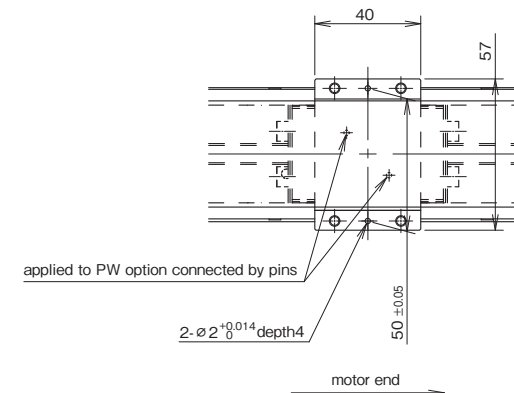

BH30A,B (long block)

- PS Option Without Top Cover -

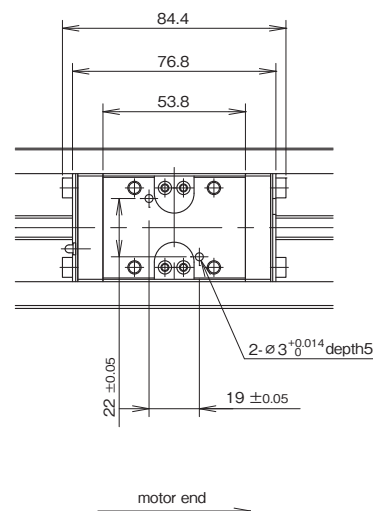

- PS Option With Top Cover -

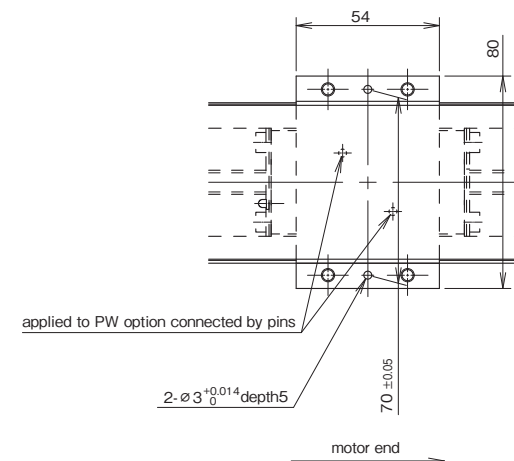

BH45A,B (long block)

- PS Option Without Top Cover -

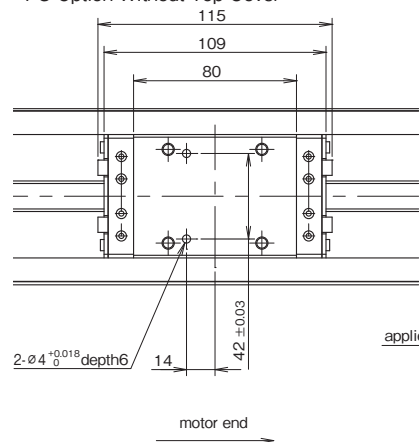

- PS Option With Top Cover -

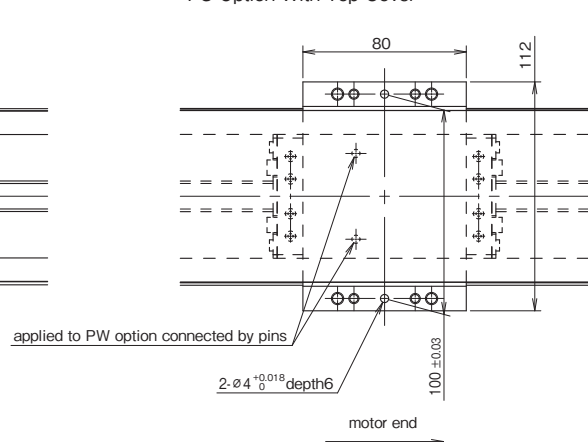

BH45C,D (short block)

- PS Option Without Top Cover -

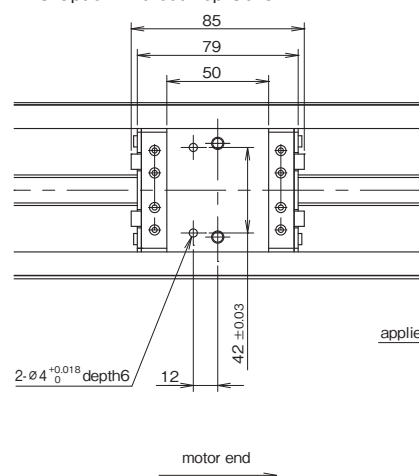

- PS Option With Top Cover -

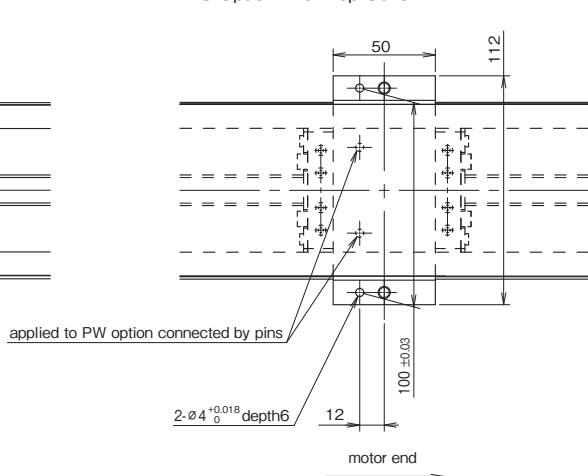

POSITIONING PIN HOLE FOR GUIDE RAIL

It is useful to use positioning pin holes on the guide rail when exacting reassembly positioning is required. NB does not supply straight pins.

After the insertion of the straight pins in the BH guide rail base, the pins might interfere with the slide block. In the positioning process, please consider the BH base thickness. The length of the pin in the BH base shall be shorter than the BH base thickness. Please make sure that the pins shall not interfere with the slide block.

Figure G-26 Positioning Pin Hole Location

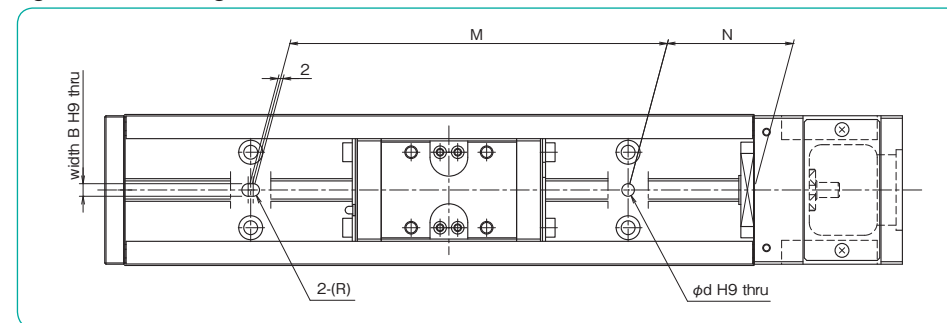

Table G-30 Positioning Pin Hole for Guide Rail

unit: mm

part number	pin length (BH base thickness)	rail length	N	M	ϕd	B
BH23	5.9 or less	150	35	80	$\phi 3^{+0.025}_0$	$\phi 3^{+0.025}_0$
		200	20	160		
		250	45			
		300	30	240		
BH30	8 or less	150	25	100	$\phi 5^{+0.030}_0$	$\phi 5^{+0.030}_0$
		200		200		
		300	300			
		400	400			
		500	500			
		600	600			
		700	700			
		750	25	700		
BH45	11 or less	340	70	200	$\phi 5^{+0.030}_0$	$\phi 5^{+0.030}_0$
		440		300		
		540		400		
		640		500		
		740		600		
		840		700		
		940		800		

Positioning pin hole option is not available for BH15.

LUBRICATION

- BH type contains a lithium soap based grease. (Multemp PS No.2, KYODO YUSHI) Apply similar type of grease for the lubrication as required depending on the operating conditions.
- For BH23, 30 use the grease fitting to lubricate the slide block. For ballscrew portion apply grease directly to the surface of screw shaft.
BH15 slide block has $\phi 2\text{mm}$ oil holes instead of grease fitting.
BH45 does not have grease fitting, apply grease directly to the raceway surface of ballscrew shaft and guide.
- Unless otherwise instructed, a grease fitting is located as shown in Figure G-27.
- The grease can be changed to a high function type by adding a special grease option at the end of the part number. Please refer to Table G-31 for the grease type.

Figure G-27 Location of Grease Fitting

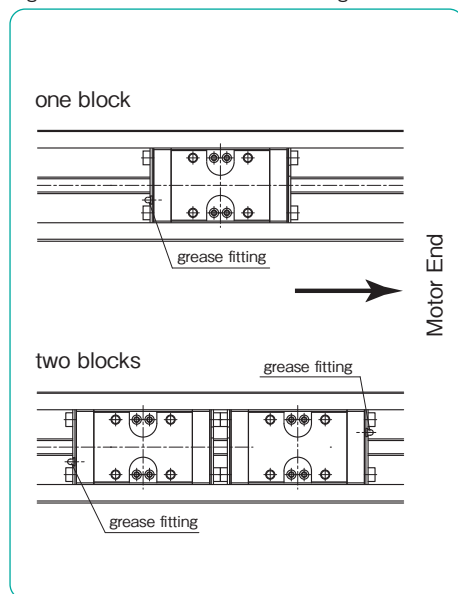

Table G-31 Applicable Grease

grease option	features	product name
none (standard)	—	Multemp PS No.2 (KYODO YUSHI)
GU	urea-type low dust generation; low sliding resistance grease	KGU Grease
GLA	lithium-type low dust generation grease	KGLA Grease
GF	urea-type anti-fretting grease	KGF Grease

ACTUATOR APPENDIX

USE AND HANDLING PRECAUTIONS

- Please handle as a precision component and avoid excessive vibration or shock.
- Rough handling will affect the smooth motion and reduce the precision performance and life time.
- DO NOT DISASSEMBLE. The accuracy of BG and BH type is preadjusted before delivery.
- Please allow for extra stroke length. If the guide block repeatedly collides with damper, it may cause damage.
- Depending upon the operating environment, dust and foreign particles may contaminate actuator and disrupt the ball circulation and precision performance.
- Please never touch the area at both stroke ends during operation. There is a danger for the fingers to be caught at the stroke end. Please pay enough attention to the guide rail area even when not in operation. There is a danger for the fingers to be injured by the dust cover.
- Anti-rust oil with little affect on the lubricant is applied to the guide rail and the block top surface. When mounting it is recommended that the turbine oil (ISO standard VG32- 64) is applied to the mounting surface for antirust effect after cleaning the contact surface.

OPERATING TEMPERATURE

- Resin parts are incorporated in the BG and BH type. Please avoid using BG and BH type above 80°C. Please use the product at 55°C or lower when sensor and/or bellows are optioned.

LUBRICATION

- The objective of lubrication includes the reduction of friction among the rolling elements as well as between the rolling elements and the raceway, prevention of sintering, reduction of wear, and the prevention of rust by forming a film over the surfaces. Please relubricate periodically depending on the operating conditions. The recommended relubrication interval is either of earlier period of about 6 months (3 months in case of 24 hours operation) or 1,000km of travel distance under normal conditions.

SENSOR SPECIFICATIONS

slim-type photomicro sensor (symbol: S) / OMRON CORPORATION

type	NPN type	EE-SX674
	PNP type	EE-SX674P
sensing distance	5 mm (slot width)	
standard sensing object	2 x 0.8 mm min. opaque object	
differential travel	0.025mm	
power supply voltage	5 to 24 V DC $\pm 10\%$, ripple(P-P): 10% max.	
current consumption	12 mA max. (NPN), 12 mA max. (PNP)	
control output	NPN type	NPN open collector output models: At 5 to 24 V DC: 100 mA load current (Ic) with a residual voltage of 0.8 V max. When driving TTL: 40 mA load current (Ic) with a residual voltage of 0.4 V max.
	PNP type	PNP open collector output models: At 5 to 24 V DC: 50 mA load current (Ic) with a residual voltage of 1.3 V max.
output operation	Dark-On (+, L terminal open-circuit), Light-On (+, L terminal short-circuit)	
response frequency	1 kHz max. (3 kHz average)	
operation indicator	operation indicator (red) lit with incident	
ambient illumination (on receiver lens)	fluorescent light: 1000 lx max.	
ambient temperature	operating: -25 to 55 °C, storage: -30 to 80 °C	
ambient humidity	operating: 5 to 85 %RH, storage: 5 to 95 %RH	
vibration resistance	destruction: 20 to 2000 Hz, (with a peak acceleration of 100 m/s ²)	
	1.5 mm double amplitude for 2 hrs (with 4-minute cycles) each in X, Y, and Z directions	
shock resistance	destruction: 500 m/s ² for 3 times each in X, Y, and Z directions	
degree of protection	IEC 60529 IP 50	
connection method	connector type (direct soldering possible)	
weight	approx. 3 g	
material	case	Polybutylene terephthalate (PBT)
	cover	Polycarbonate (PC)
	emitter/receiver	

NPN type
CIRCUIT DIAGRAM

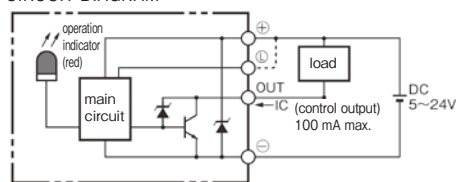

PNP type
CIRCUIT DIAGRAM

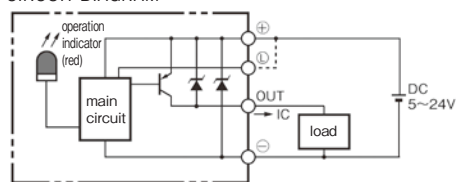

Please read the specifications and precautions of the manufacturer's catalogs or instruction manuals.

compact photomicro sensor (symbol: S) / Panasonic Industrial Devices SUNX Co., Ltd.

type	NPN type	PM-L25
	PNP type	PM-L25-P
sensing range	6 mm (fixed)	
minimum sensing object	0.8 x 1.2 mm opaque object	
hysteresis	0.05 mm or less	
repeatability	0.01 mm or less	
supply voltage	5 to 24 V DC $\pm 10\%$, ripple (P-P): 10% or less	
current consumption	15 mA or less	
control output	NPN type	NPN open-collector transistor maximum sink current: 50 mA, applied voltage: 30 V DC or less (between output and 0 V) residual voltage: 2 V or less (at 50 mA sink current) 1 V or less (at 16 mA sink current)
	PNP type	PNP open-collector transistor maximum source current: 50 mA, applied voltage: 30 V DC or less (between output and + V) residual voltage: 2 V or less (at 50 mA sink current) 1 V or less (at 16 mA sink current)
output operation	incorporated with 2 outputs: Light-ON/Dark-ON	
response time	under light received condition: 20 μ s or less, under light interrupted condition: 80 μ s or less (response frequency: 3 kHz or more)	
operation indicator	orange LED (lights up under light received condition)	
ambient illuminance	fluorescent light: 1000 lx at the light-receiving face	
ambient temperature	operating: -25 to 55 °C (No dew condensation or icing allowed.), storage: -30 to 80 °C	
ambient humidity	5 to 85 %RH, storage: 5 to 95 %RH	
voltage withstandability	1000 V AC for one min. between all supply terminals connected together and enclosure	
insulation resistance	20 M Ω , or more, with 250 V DC megger between all supply terminals connected together and enclosure	
vibration resistance	10 to 2,000 Hz frequency, 1.5 mm double amplitude (maximum acceleration 196 m/s ²) in X, Y, and Z directions for two hours each	
shock resistance	15,000 m/s ² acceleration (1,500 G approx.) in X, Y, and Z directions three times each	
cable	0.09 mm ² 4-core cabtyre cable, PVC, 1 m long	
weight	Net weight: 10 g approx., Gross weight: 15 g approx.	
material	case	Polybutylene terephthalate (PBT)
	cover	Polycarbonate (PC)
	emitter/receiver	

NPN type
CIRCUIT DIAGRAM

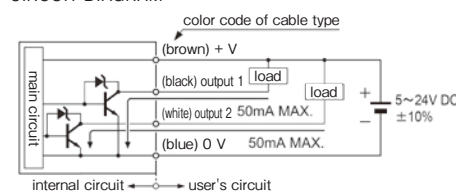

PNP type
CIRCUIT DIAGRAM

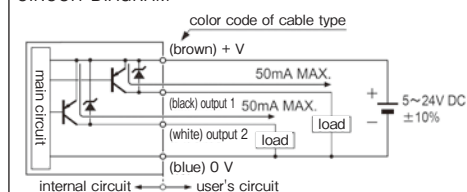

Please read the specifications and precautions of the manufacturer's catalogs or instruction manuals.

proximity sensor (symbol: K)/ Azbil CORPORATION

type	NPN type	APM-D3B1,APM-D3B1F (different-frequency type)
	PNP type	APM-D3E1,APM-D3E1F (different-frequency type)
rated sensing distance	2.5mm±15%	
standard target object	15x15 mm, 1 mm thick iron	
differential travel	15 % max. of sensing distance	
rated supply voltage	12/24 V DC	
operating voltage range	10.8 to 26.4 V DC	
current consumption	10 mA max.	
control output	NPN type	NPN transistor open collector switching current: 30 mA max. (resistive load) voltage drop: 1 V max. (switching current 30 mA) output dielectric strength: 26.4 V
	PNP type	PNP transistor open collector switching current: 30 mA max. (resistive load) voltage drop: 1 V max. (switching current 30 mA) output dielectric strength: 26.4 V
operation mode	normally closed (N.C.)	
operating frequency	120Hz	
indicator lamps	lights (red) when object approaches	
operating temperature range	-10 to 55 °C , storage: -25 to 70 °C	
operating humidity range	35 ~ 85%RH	
dielectric strength	1000 V AC (50/60 Hz) for one min. between case and electrically live metals	
insulation resistance	50 MΩ min. (by 500 V DC megger)	
vibration resistance	10 to 55 Hz, 1.5 mm peak-to-peak amplitude, 2 hrs in X, Y, and Z directions	
shock resistance	500 m/s ² 3 times in X, Y, and Z directions	
protection	IP 67 (IEC 529)	
weight	approx. 10 g excl. cable (length of cable: 1 m)	

NPN type
CIRCUIT DIAGRAM

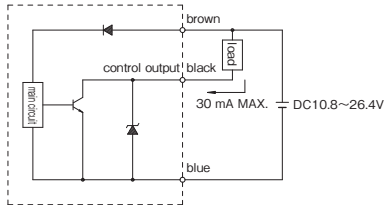

PNP type
CIRCUIT DIAGRAM

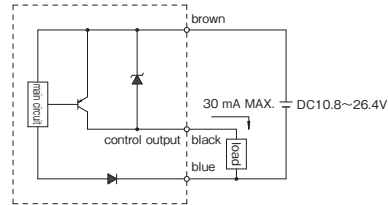

Please read the specifications and precautions of the manufacturer's catalogs or instruction manuals.